

Universität Innsbruck  
Seminar aus Rechtstheorie und Rechtsinformatik  
21. – 22. April 2004

# Visualisierung der Zeit

*Univ.-Prof. Dr. Friedrich Lachmayer*

*21. April 2004*

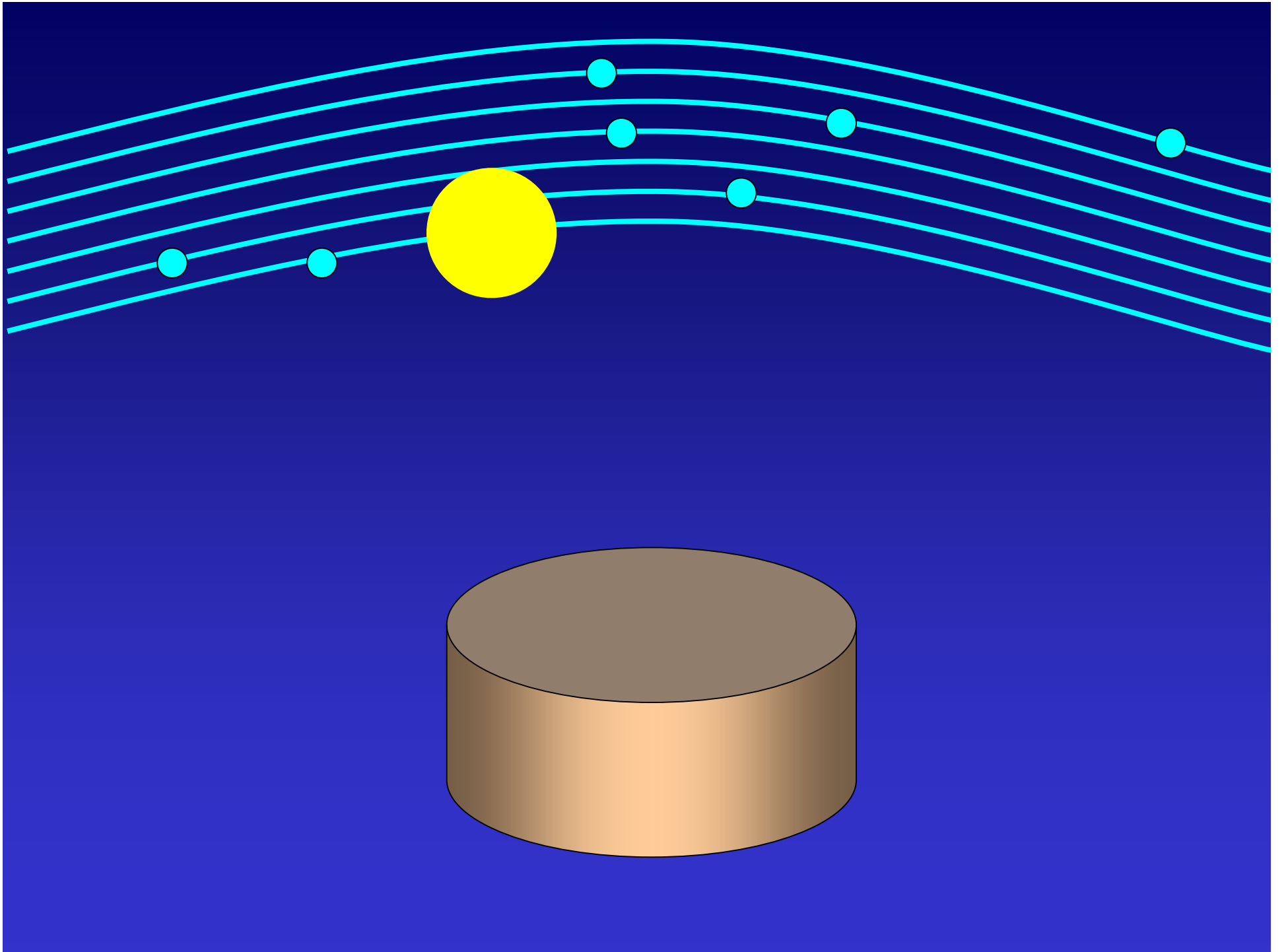

Rätsel der „Zeit“

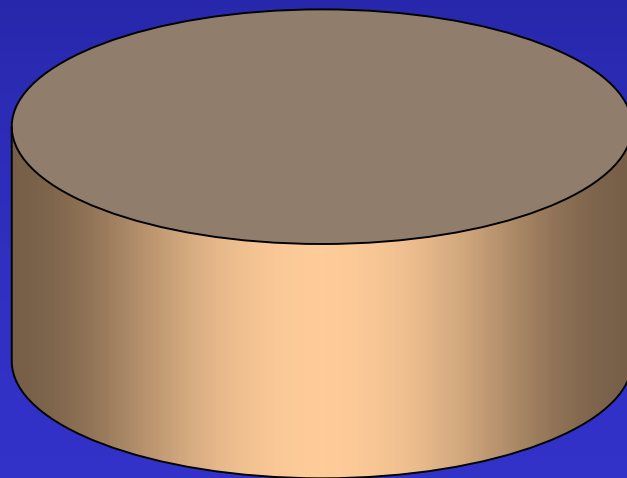

# **„Kontinuität“ des Subjektes**

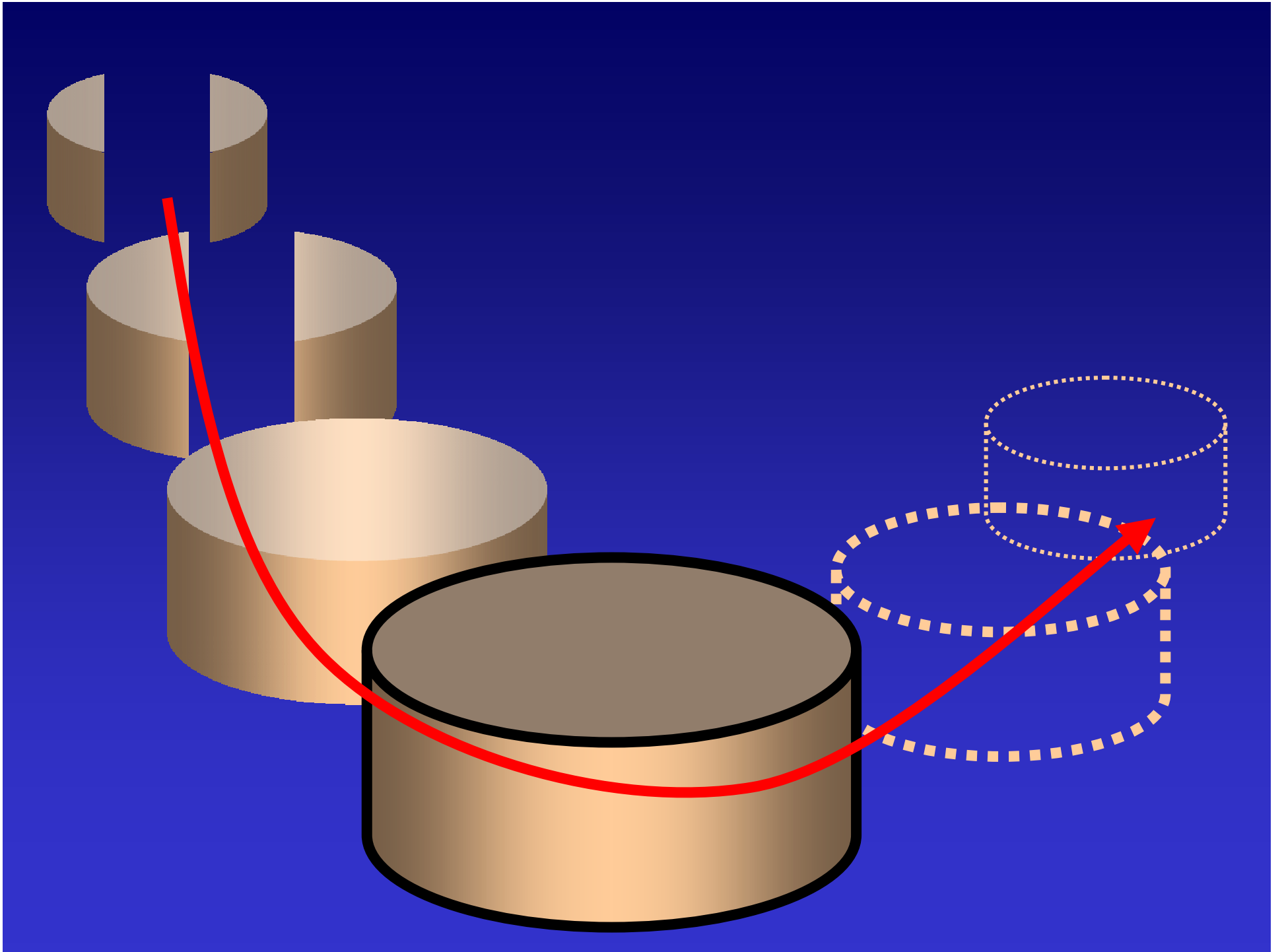

# Zeitperspektiven

Vergangenheit

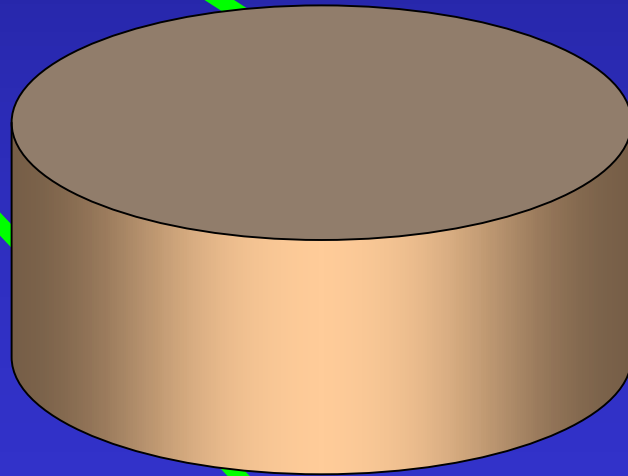

Vergangenheit

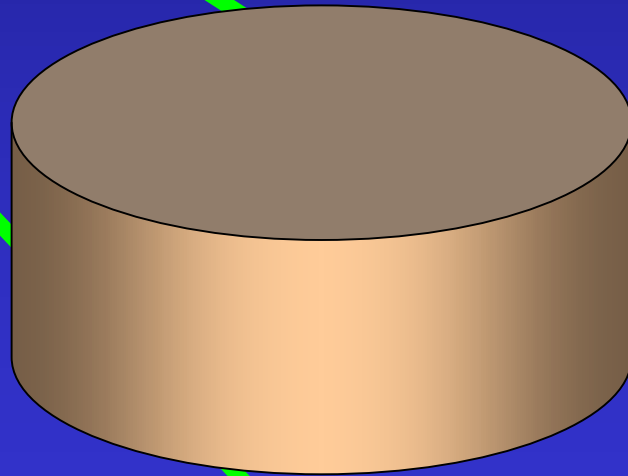



**Gegenwart**

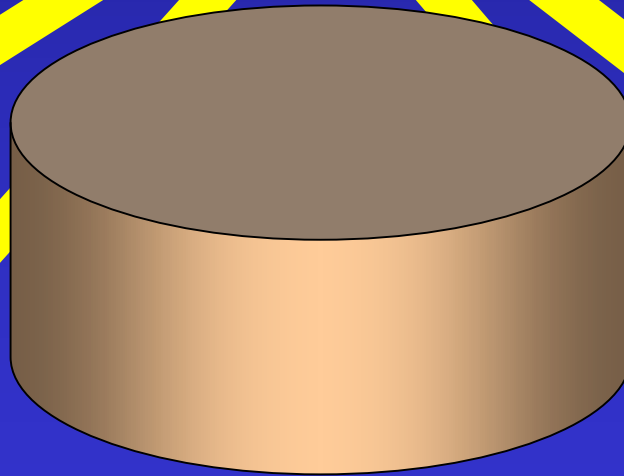

Zukunft

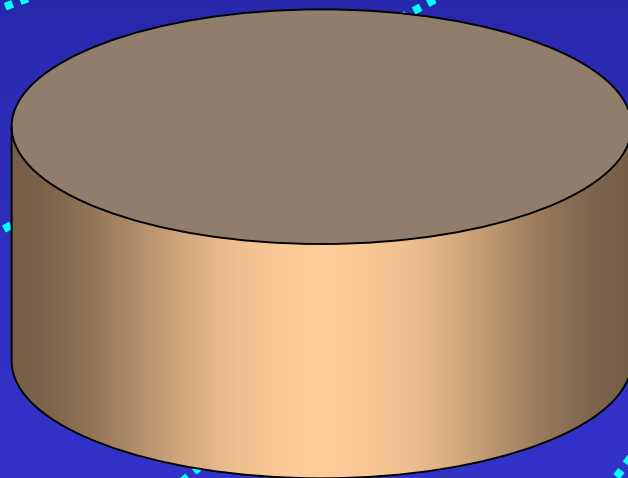

**Tönend wird für Geistes-Ohren  
schon der neue Tag geboren**

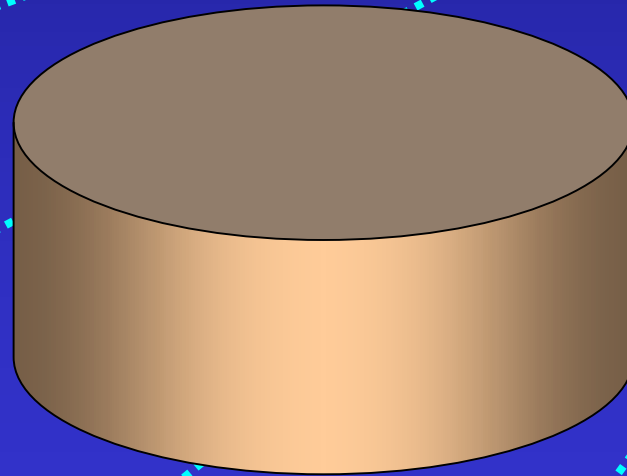

**Tönend wird für Geistes-Ohren  
schon der neue Tag geboren**

**Welch Getöse  
bringt das Licht!**

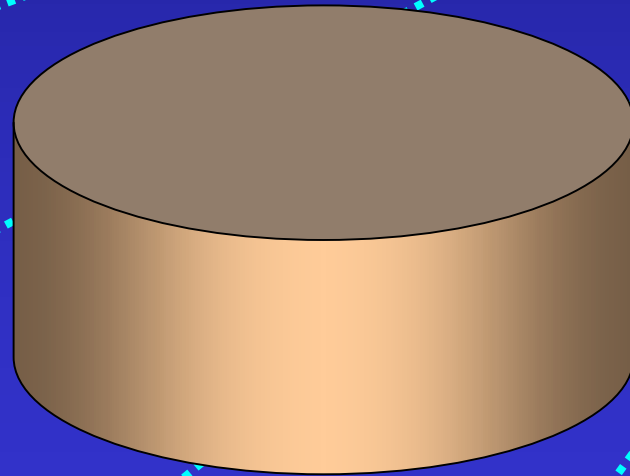

# Distanzgegenwart

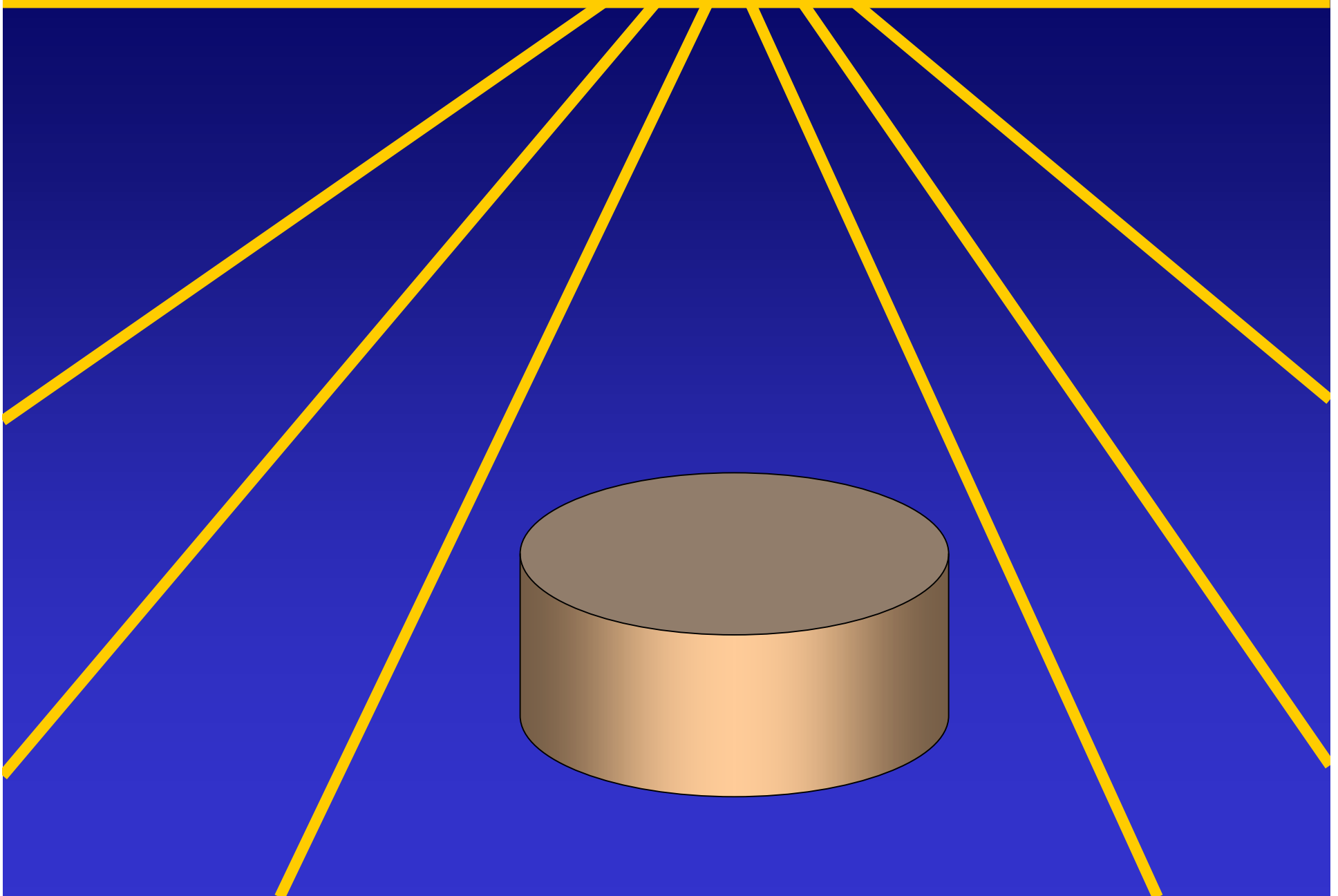

# Distanzgegenwart

Handy

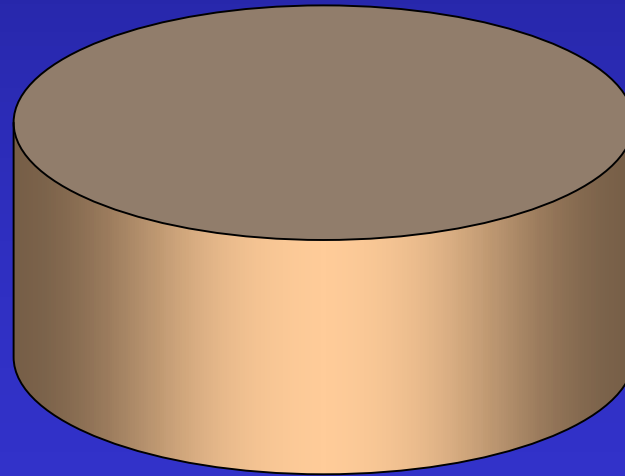

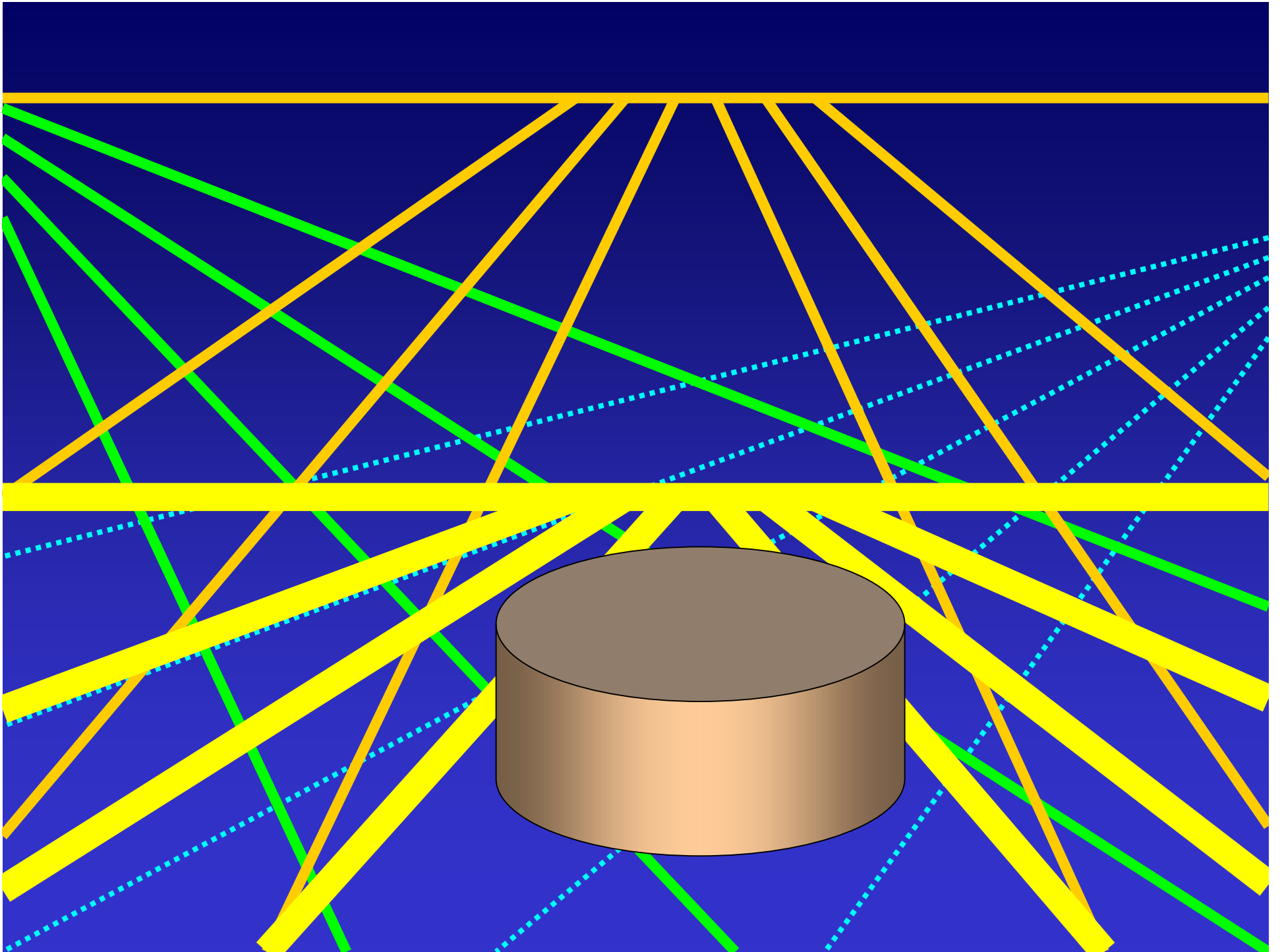

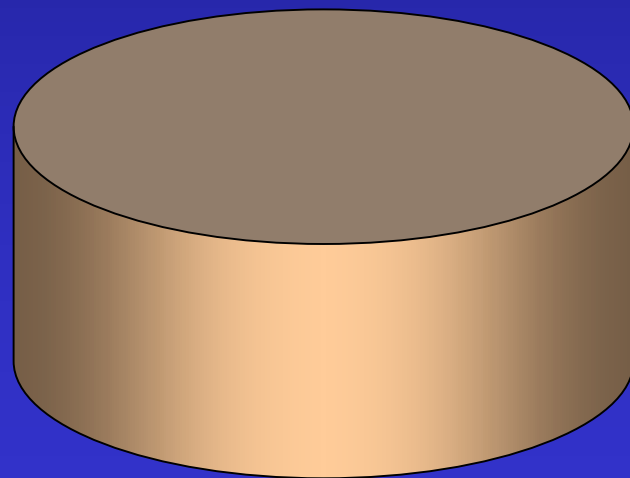



# Gegenwartsbewusstsein und Zeitlosigkeit

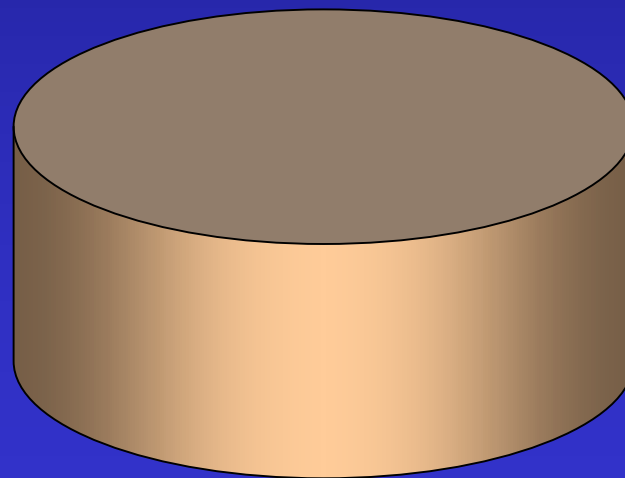

**Deutung  
durch Vergangenheit**

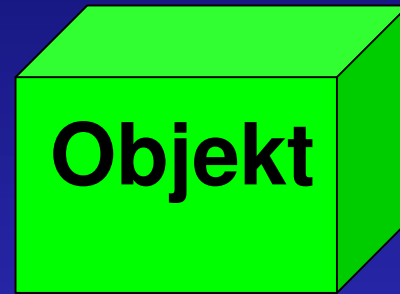

**Situation**

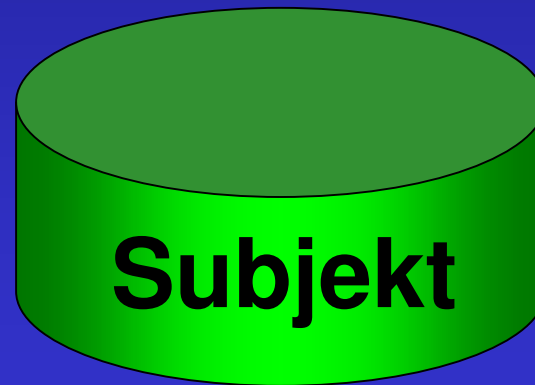

# Deutung über die Vergangenheit

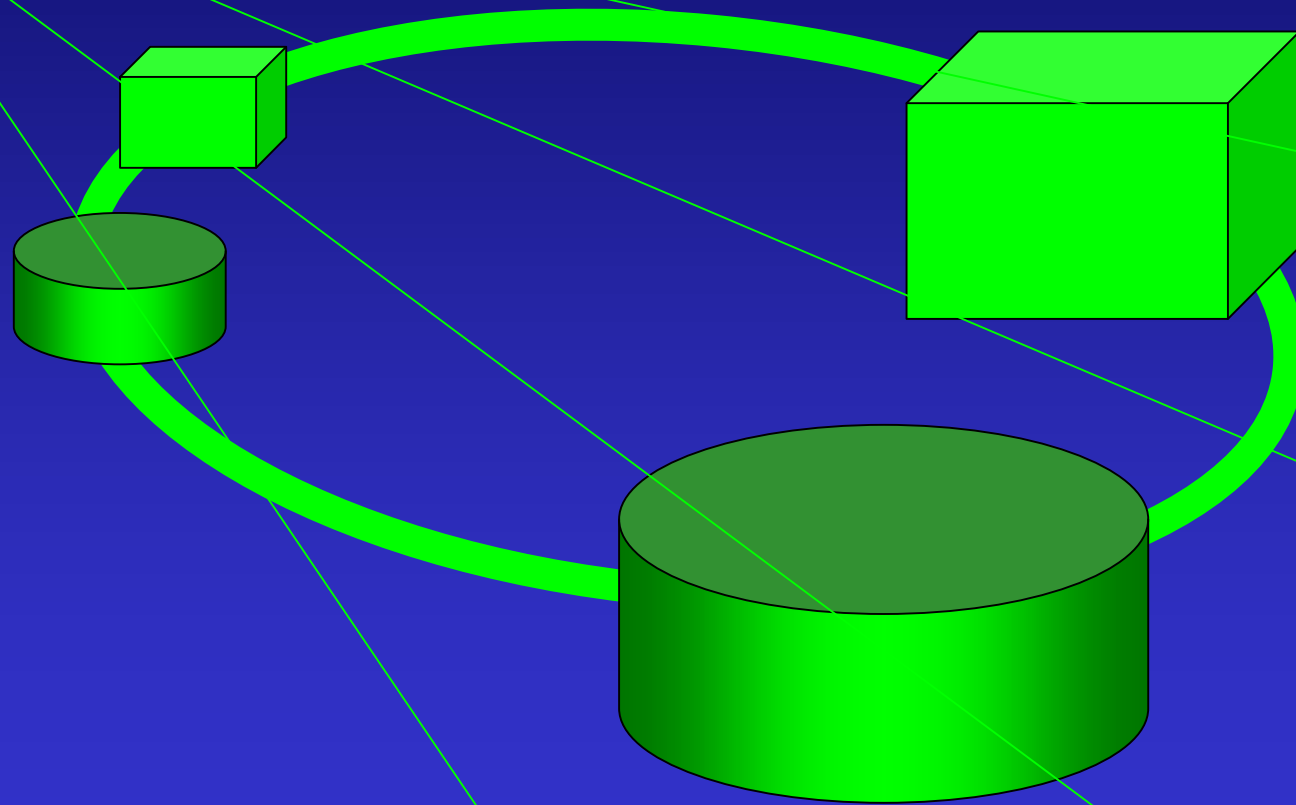

**Muster-Erkennung**

# Deutung über die Vergangenheit

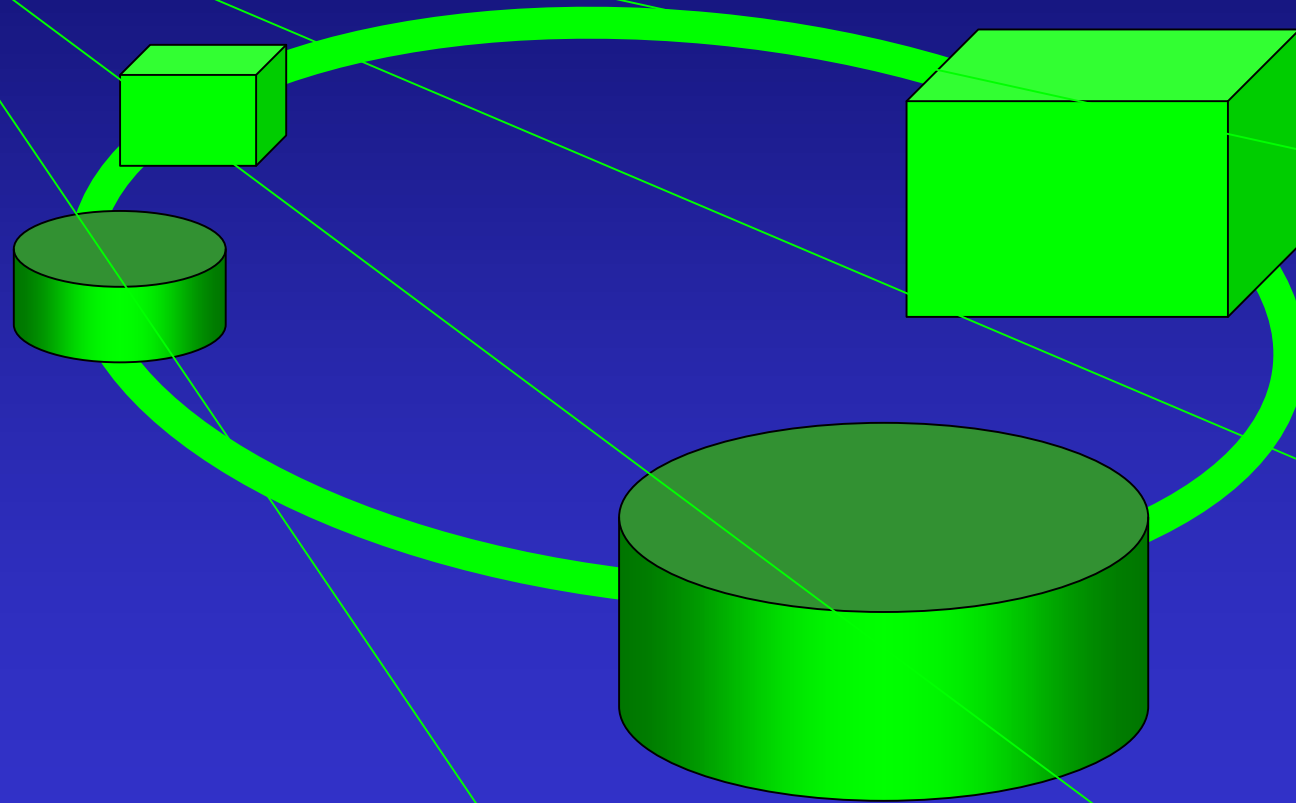

„Mutter“-Erkennung

**Deutung  
durch Vergangenheit**

**Deutung  
durch Sprache**

# Benennung durch Sprache

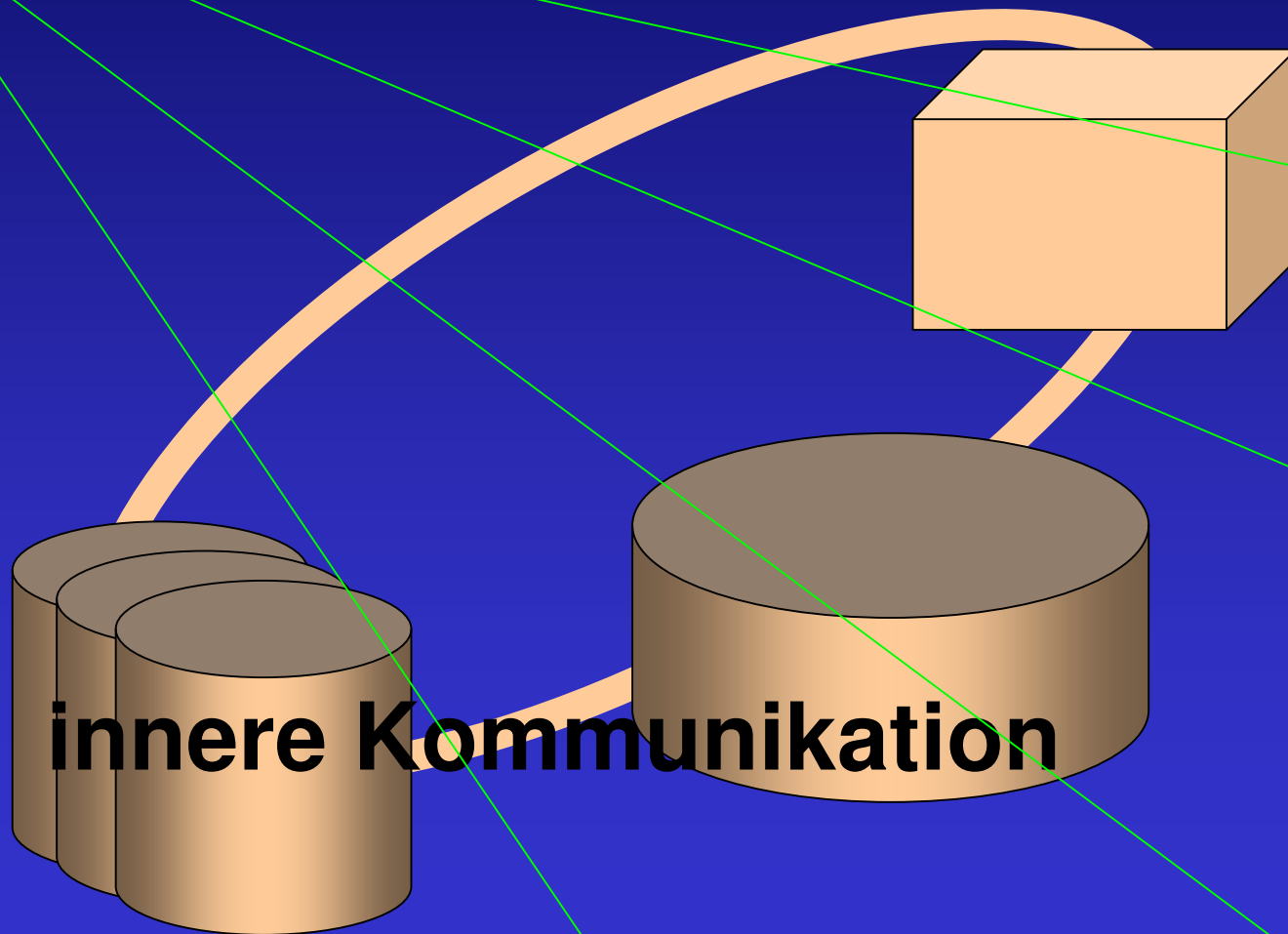

# Benennung durch Sprache

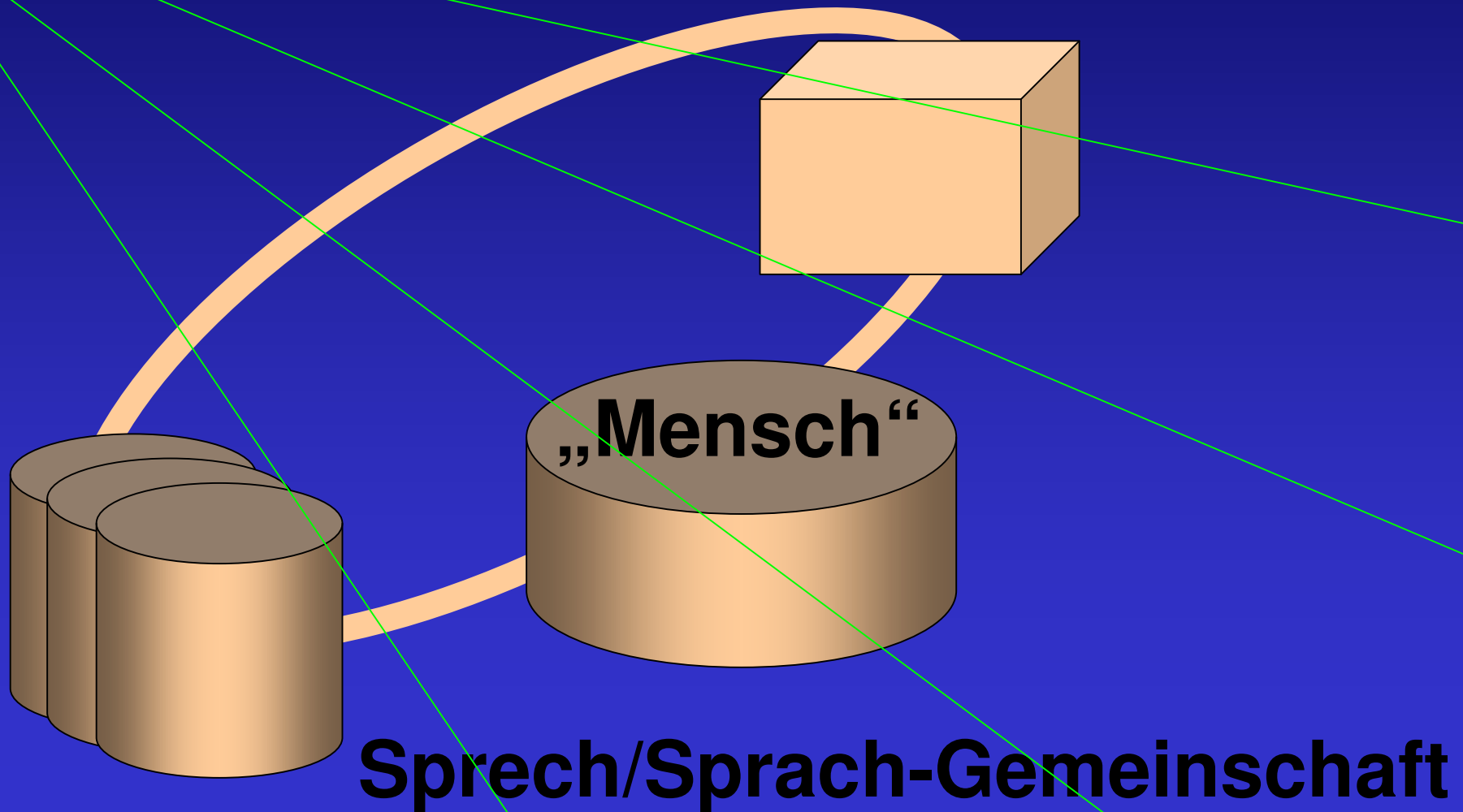



**UNIVERSALIA ANTE REM**

# Benennung durch Sprache

**Lexikon, Grammatik**

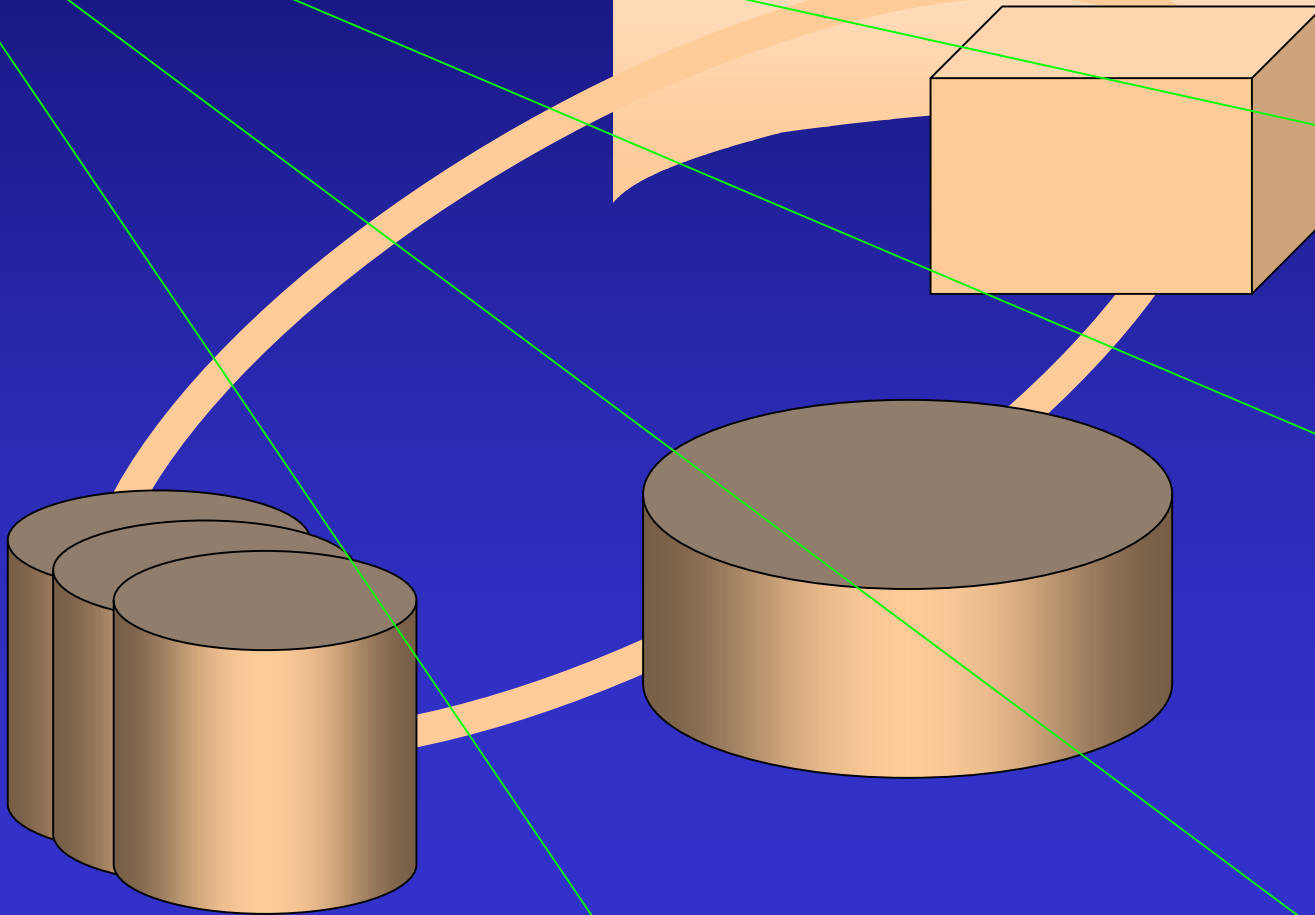

**Animismus**

**Bannen  
durch Sprache  
„Nomen“**

**UNIVERSALIA TRANS REM**

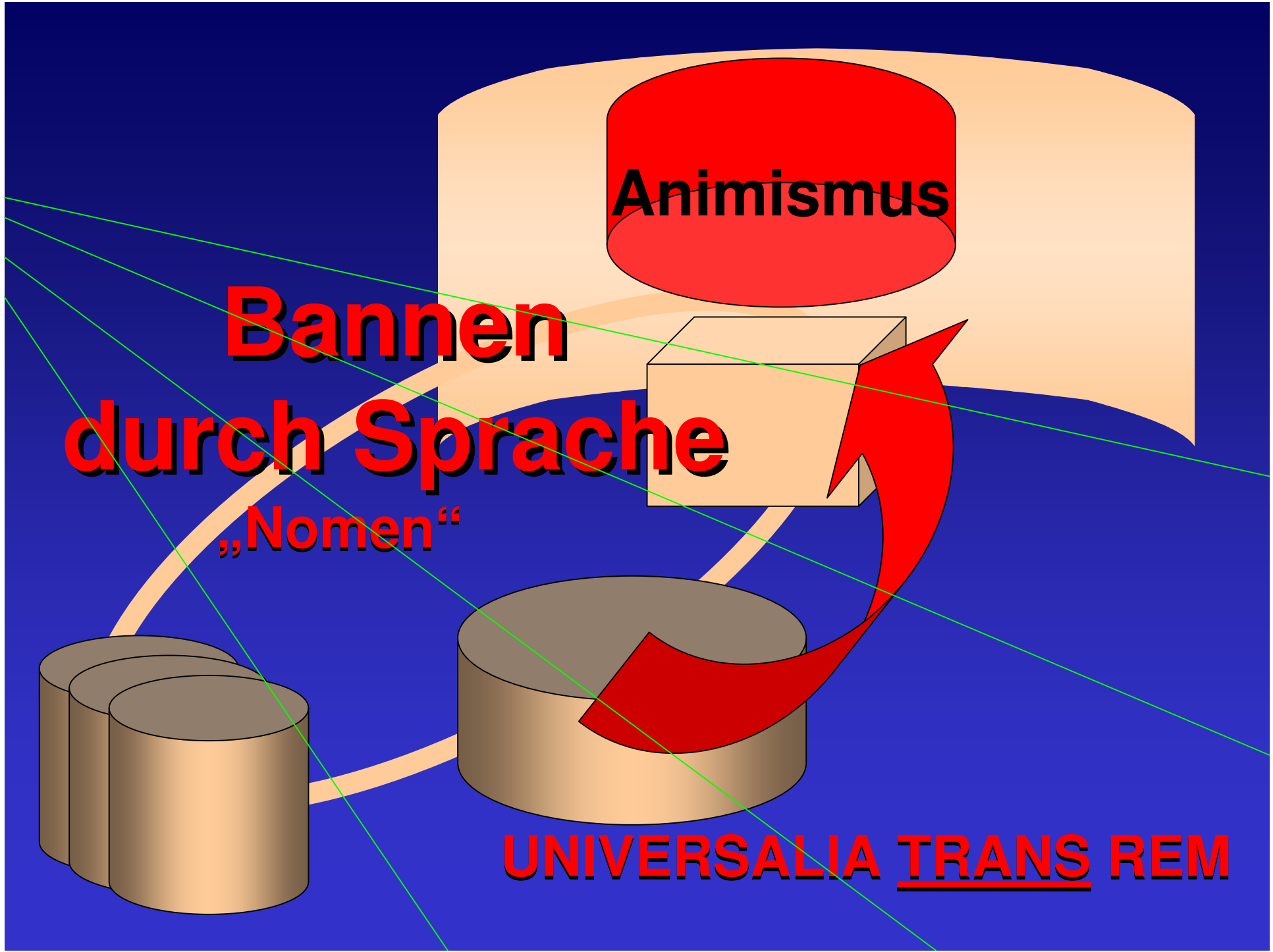

# Zeit-Einheiten

*Von „12 hoch“ zu „10 hoch“*

**Zehntelsekunde: Gedanke**

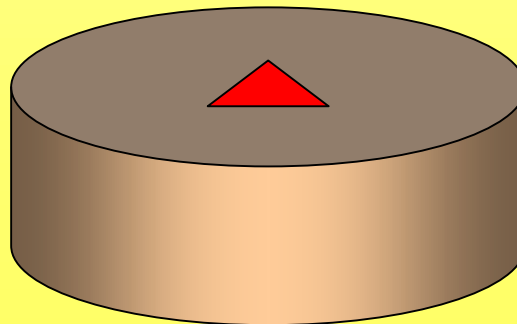

**Sekunde: Aktion**

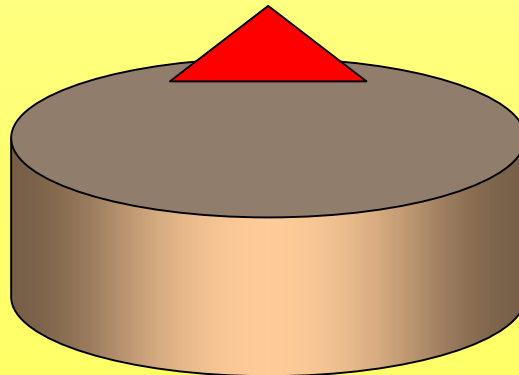

**Minute: Situation**

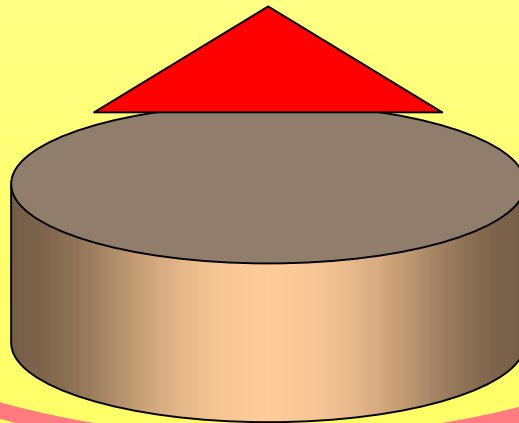

**Stunde: Produkt**

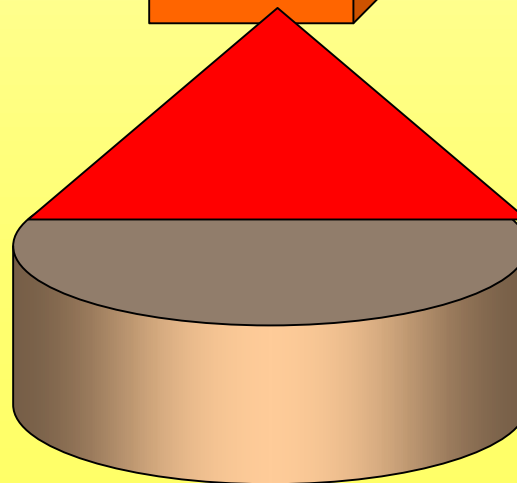
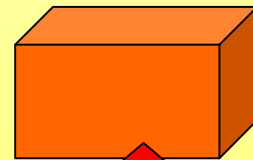

**Tag: natürliche Einheit**

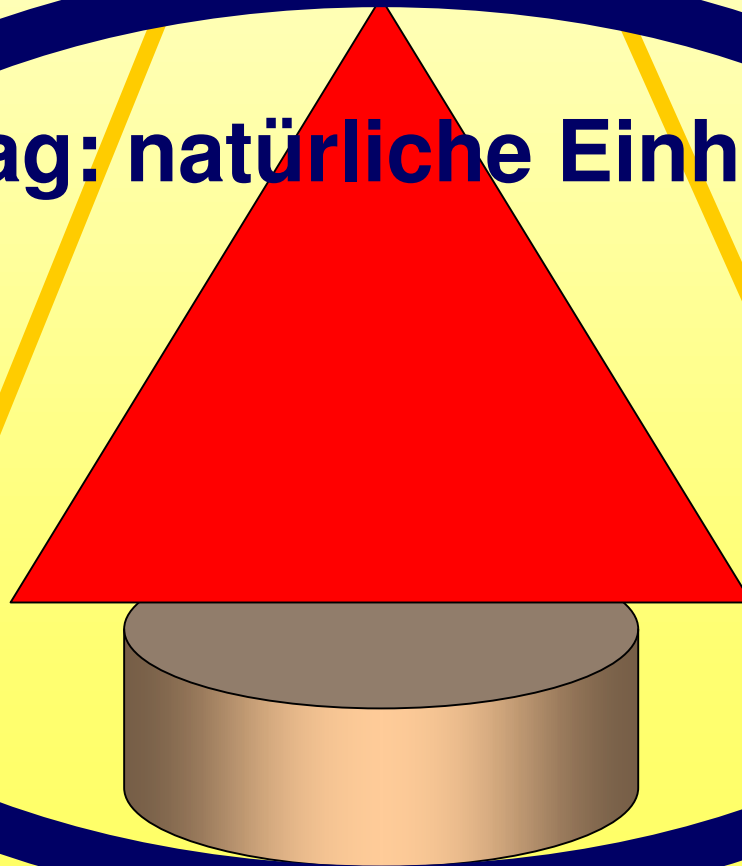



**Woche: soziale Einheit**

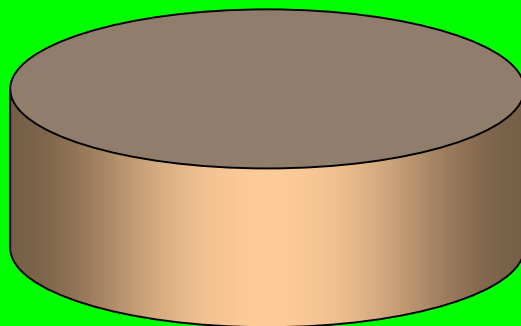

**Monat: Mond**

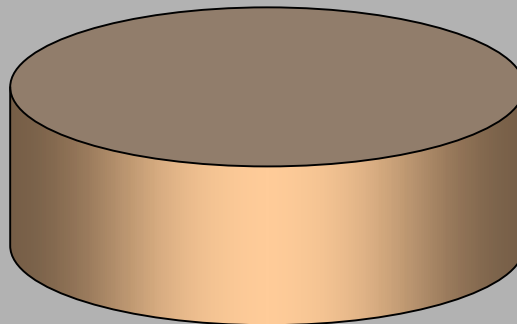

**Jahr: Sonne**

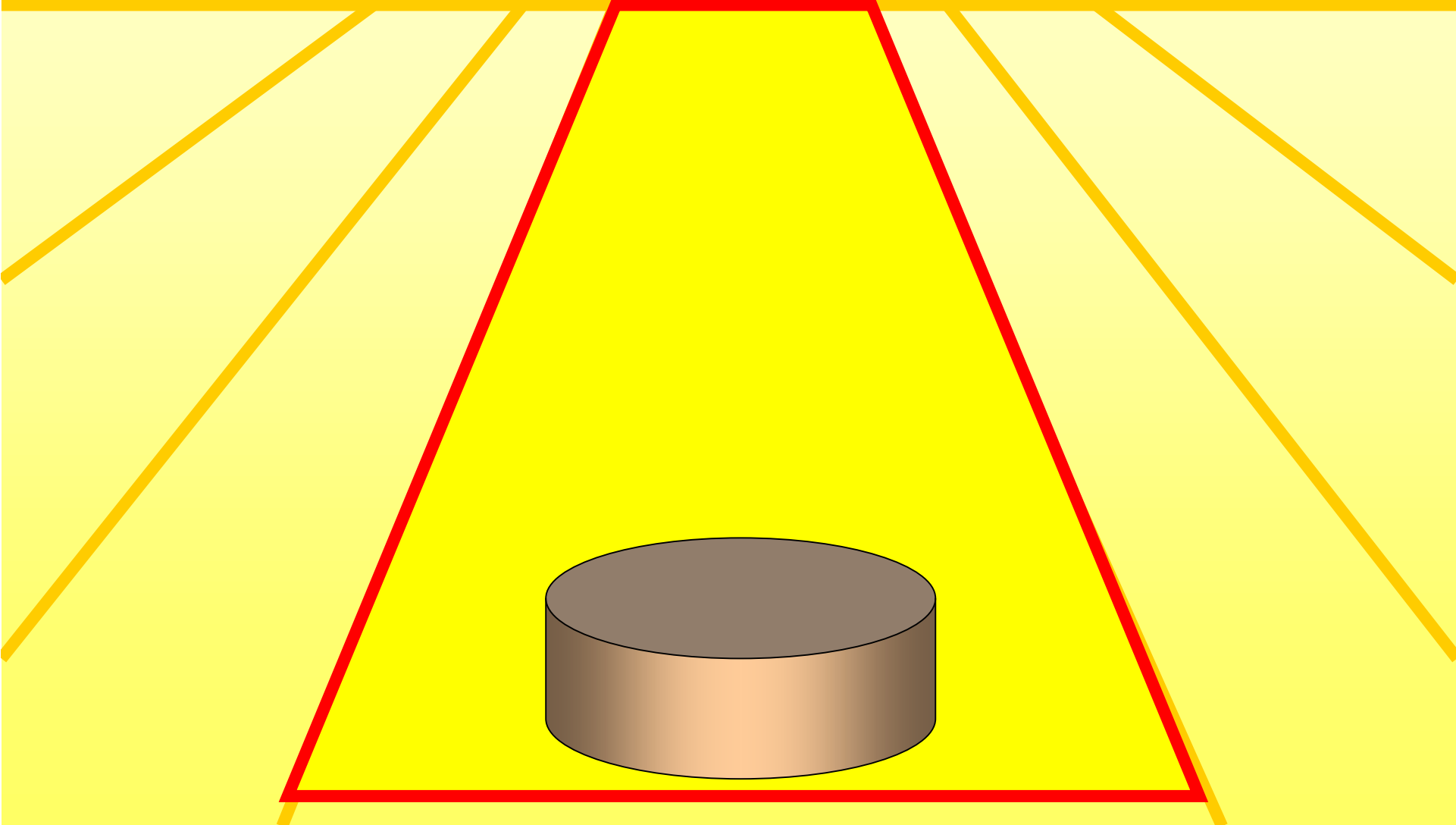

**10 Jahre: Lebensabschnitt**

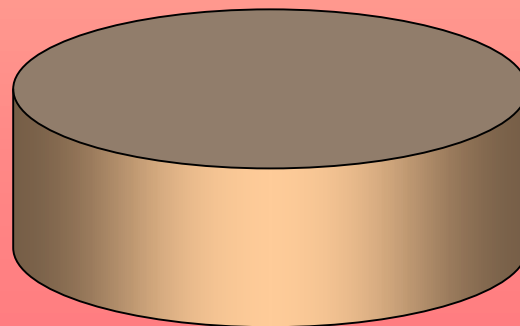

**100 Jahre: Lebensdauer**

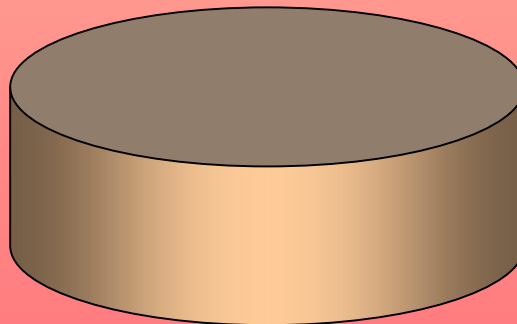

**1 000 Jahre: Kulturen**

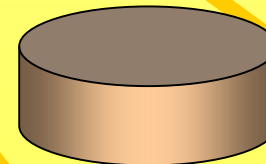
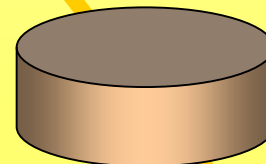
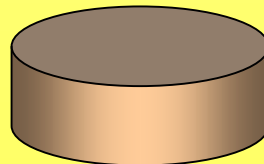
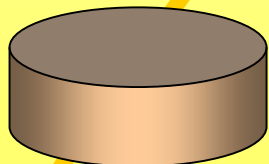
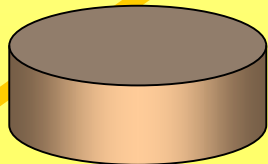

**10 000 Jahre: Nacheiszeit**



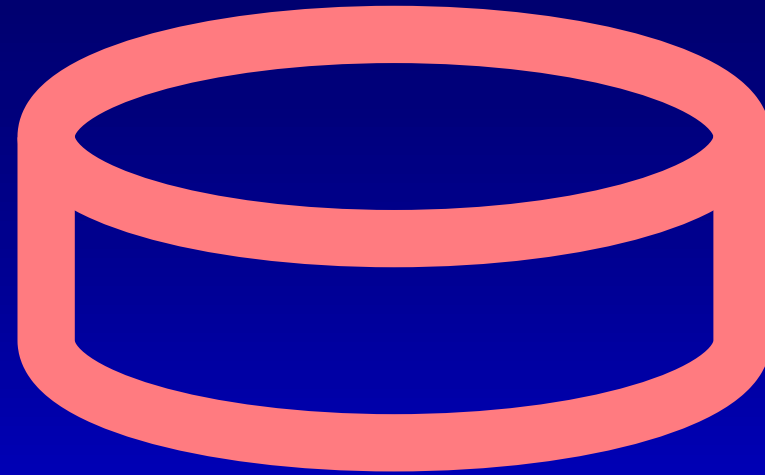

**100 000 Jahre: Neanderthaler**

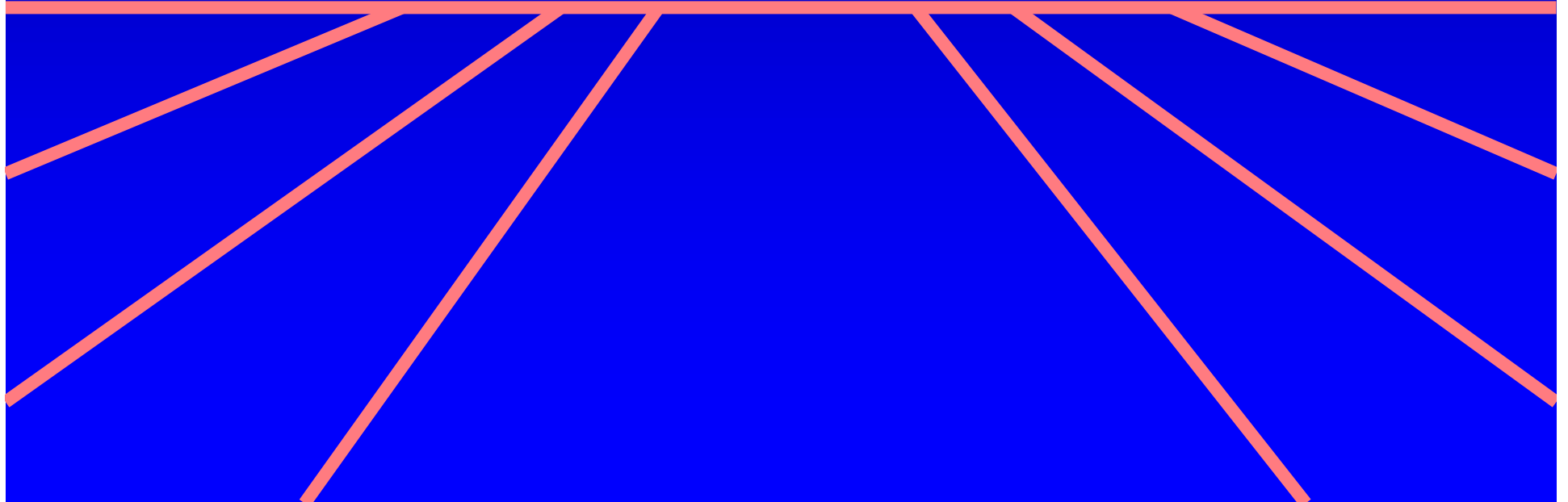



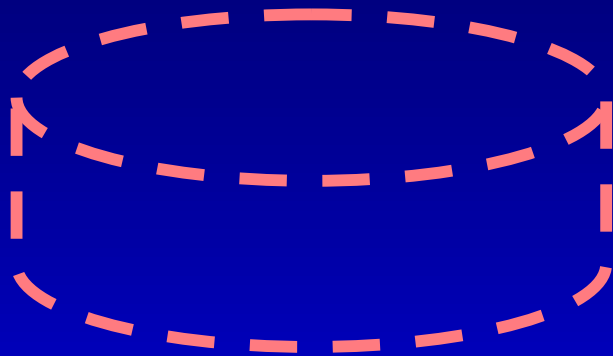

**1 Mio Jahre: Hominiden**

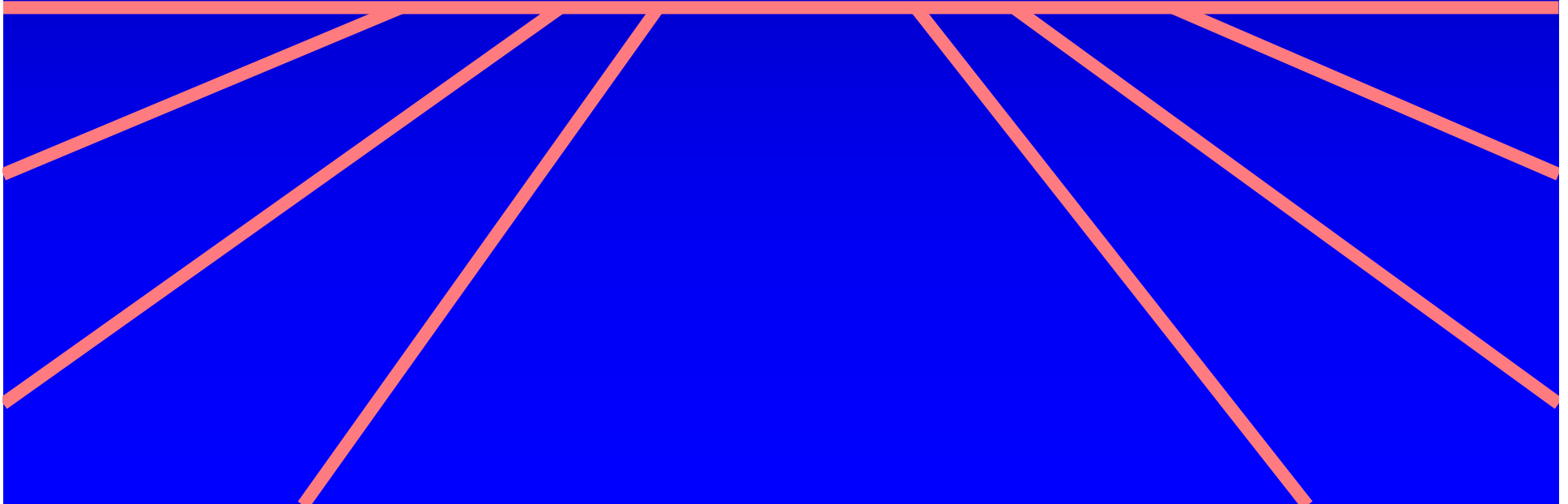

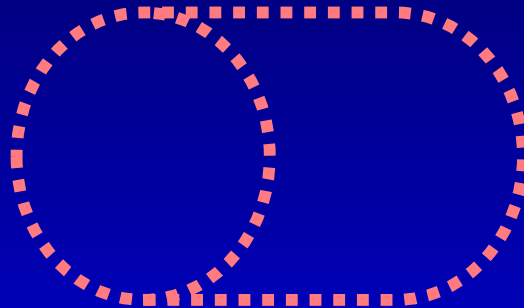

**10 Mio Jahre: Primaten**

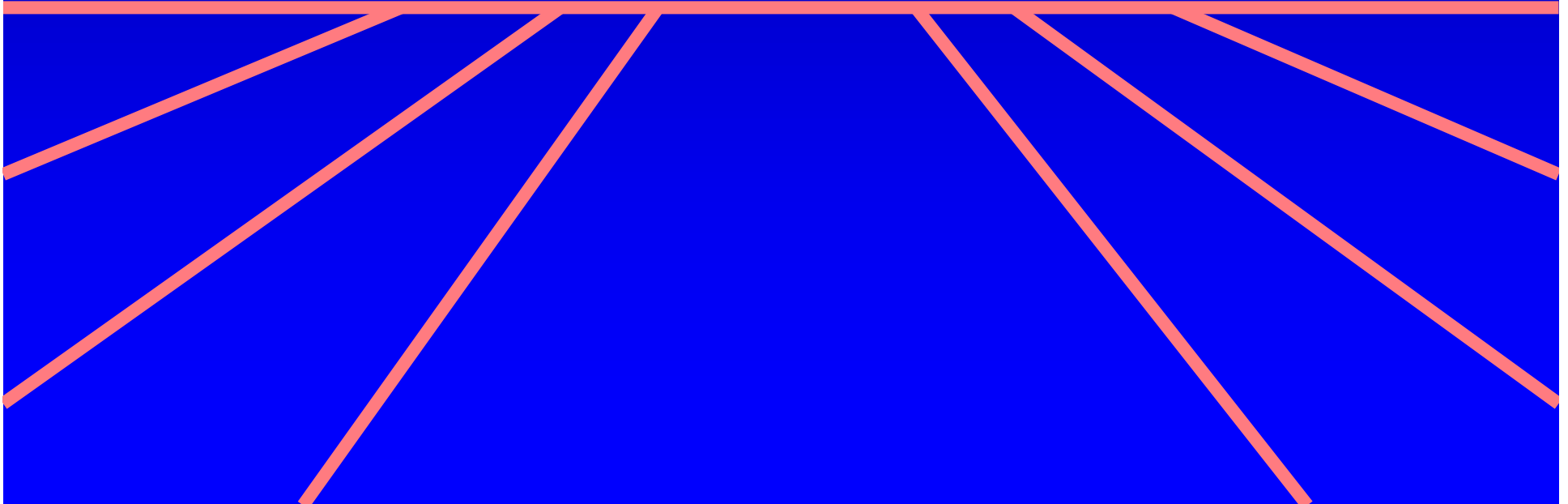

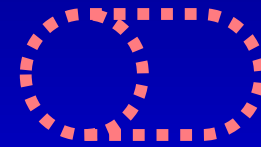
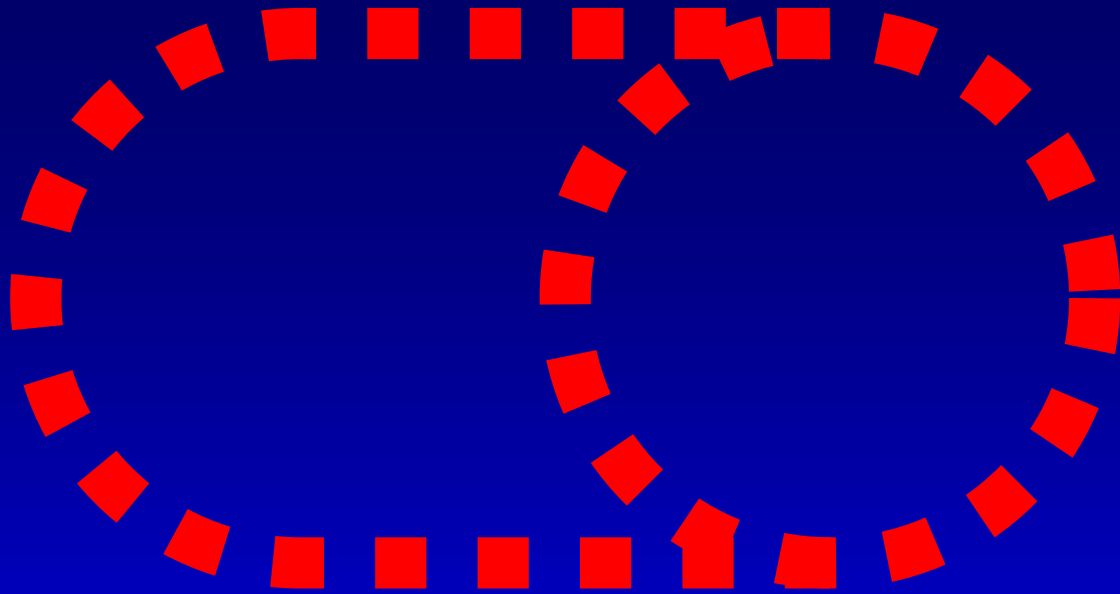

**100 Mio Jahre: Dinosaurier / Mammalia**

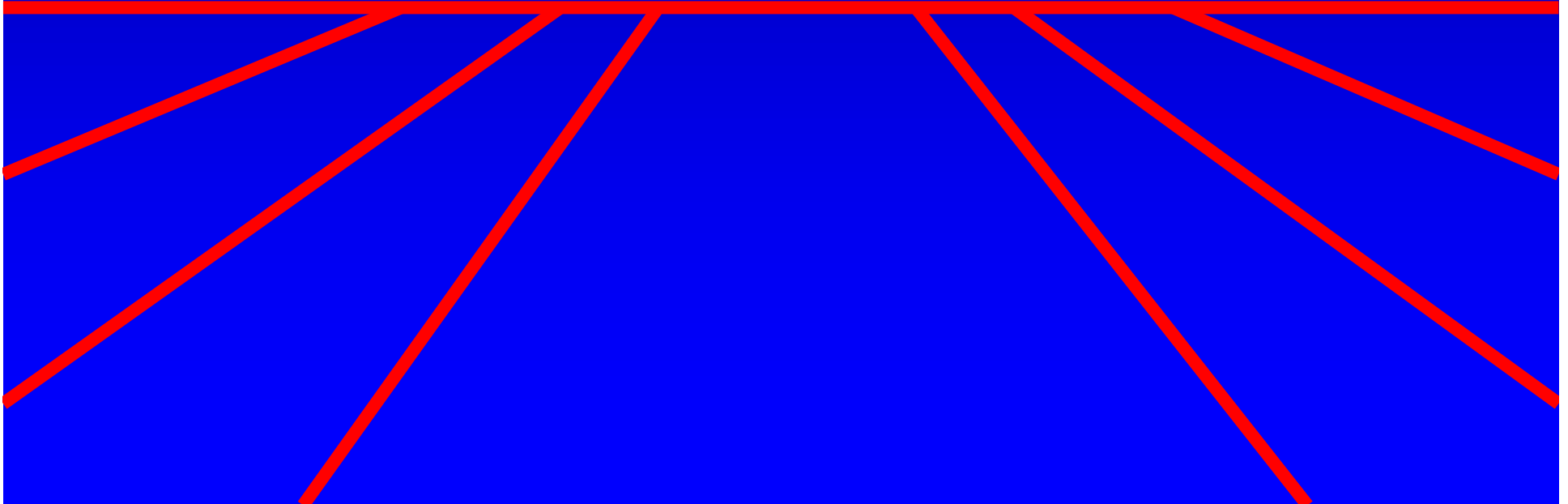



1 Mrd Jahre: Meeresbewohner

**10 Mrd Jahre: Galaxien**

**Zehntelsekunde: Gedanke**

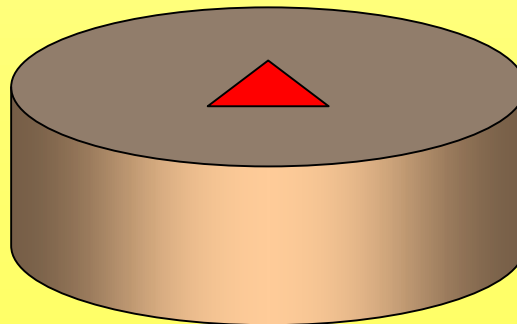

**1/100 Sekunde: Maschinenzeit  
Fotoblende**

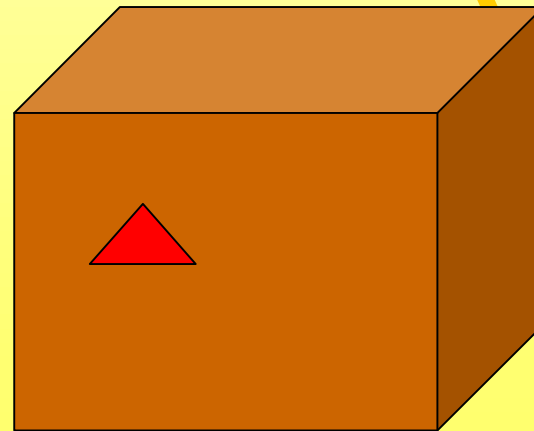
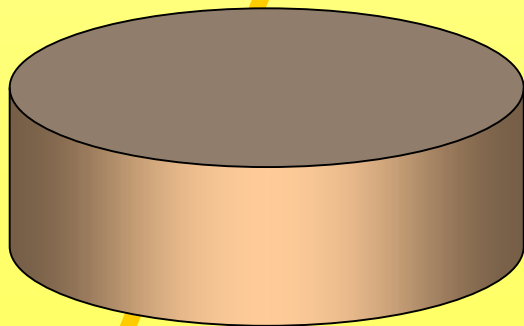



The diagram illustrates the light path through a camera lens during a 1/1000 second exposure. A horizontal yellow line at the top represents the light source. Six yellow lines radiate downwards from this line, representing light rays. These rays pass through a brown rectangular box representing the camera's lens and shutter. A small red triangle is positioned on the front surface of the lens box, indicating the focal point. The text '1/1 000 Sekunde: Maschinenzeit Fotoblende' is displayed in white on the front face of the lens box.

**1/1 000 Sekunde: Maschinenzeit  
Fotoblende**





**1/10 000 Sekunde: Maschinenzeit**



**1/100 000 Sekunde: Maschinenzeit**

**Von der  
situativen Zeit**

**zur  
Uhren-Zeit**



rechtzeitig

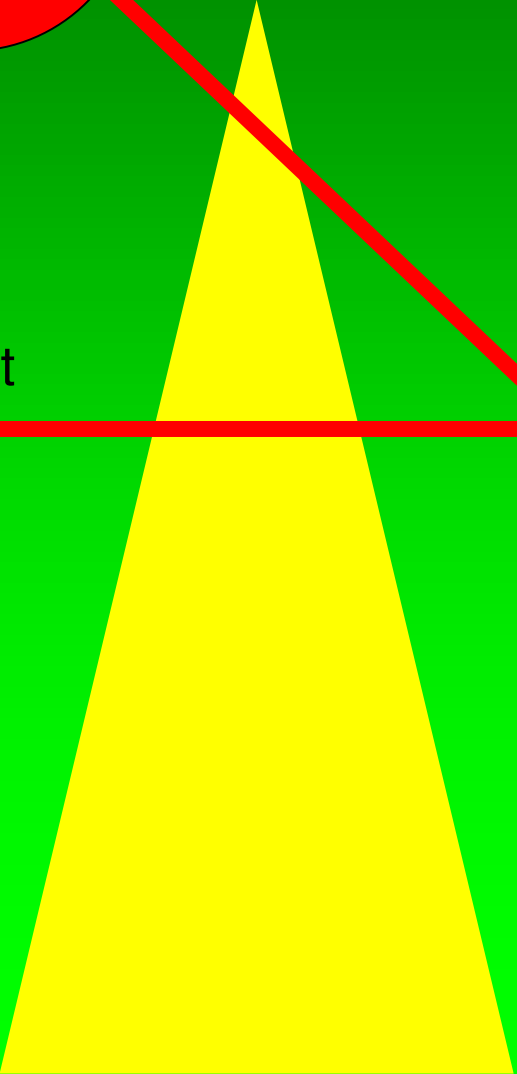
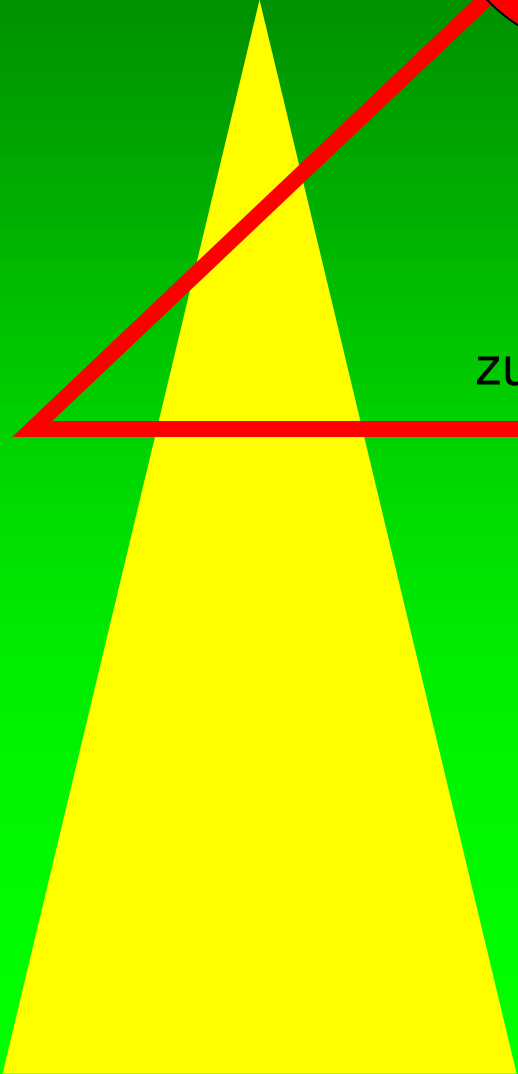
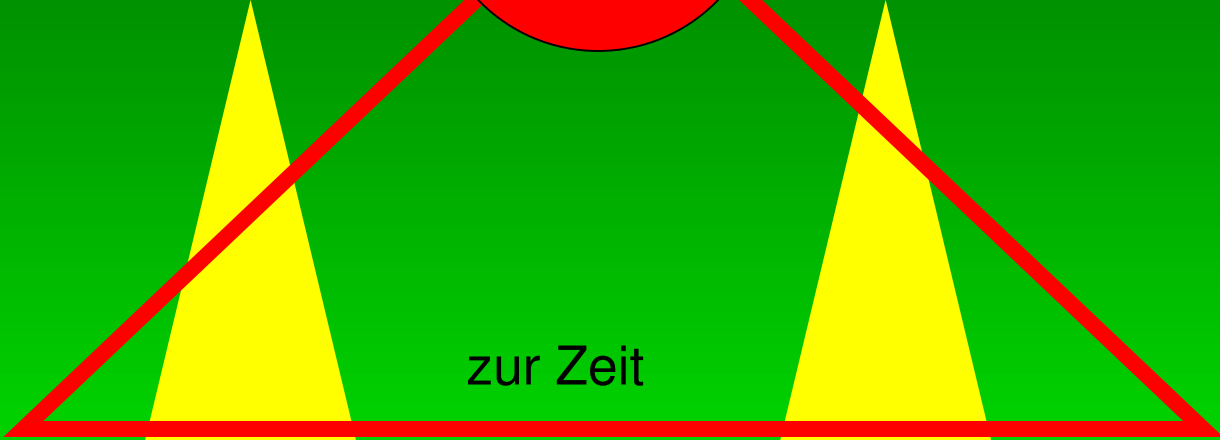
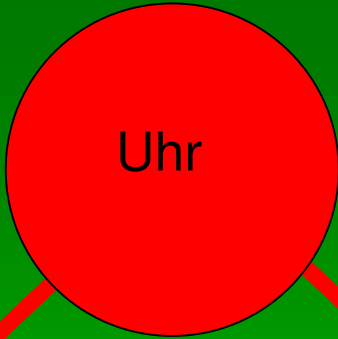

symbolische Verfügbarkeit von Zukunft auf der Metaebene

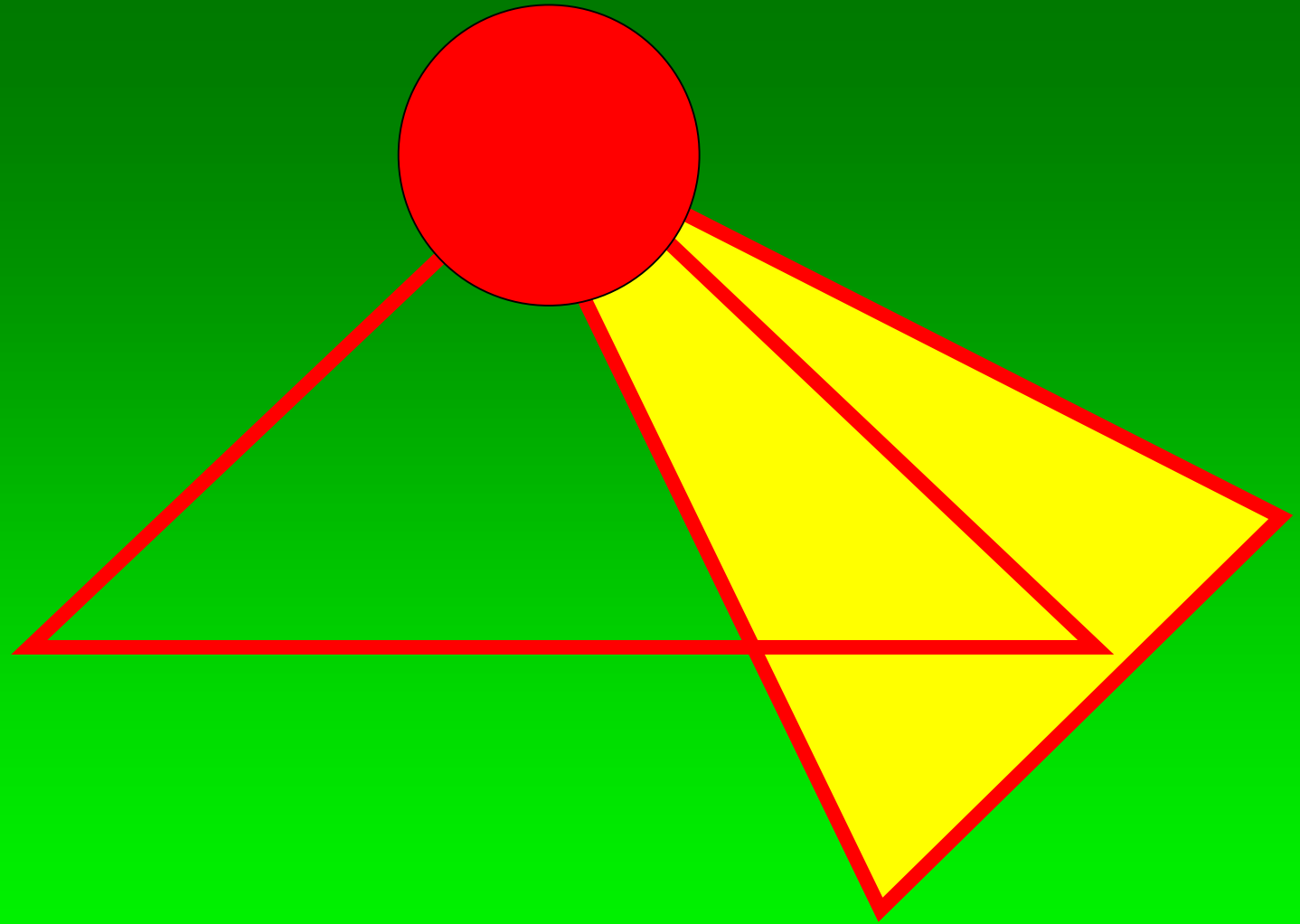



Alternativzeiten

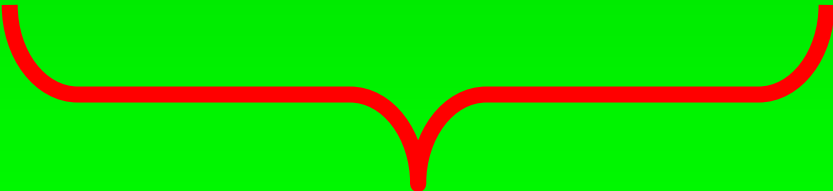

Alternativen

Konjunktiv

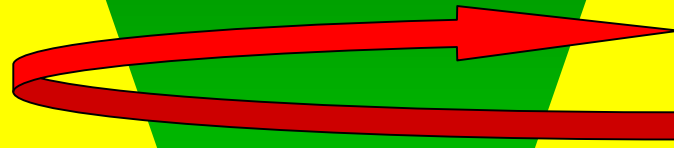

Alternativzeiten

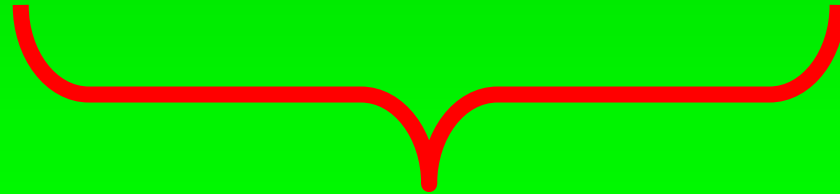

Alternativen



# Zeit-Notationen

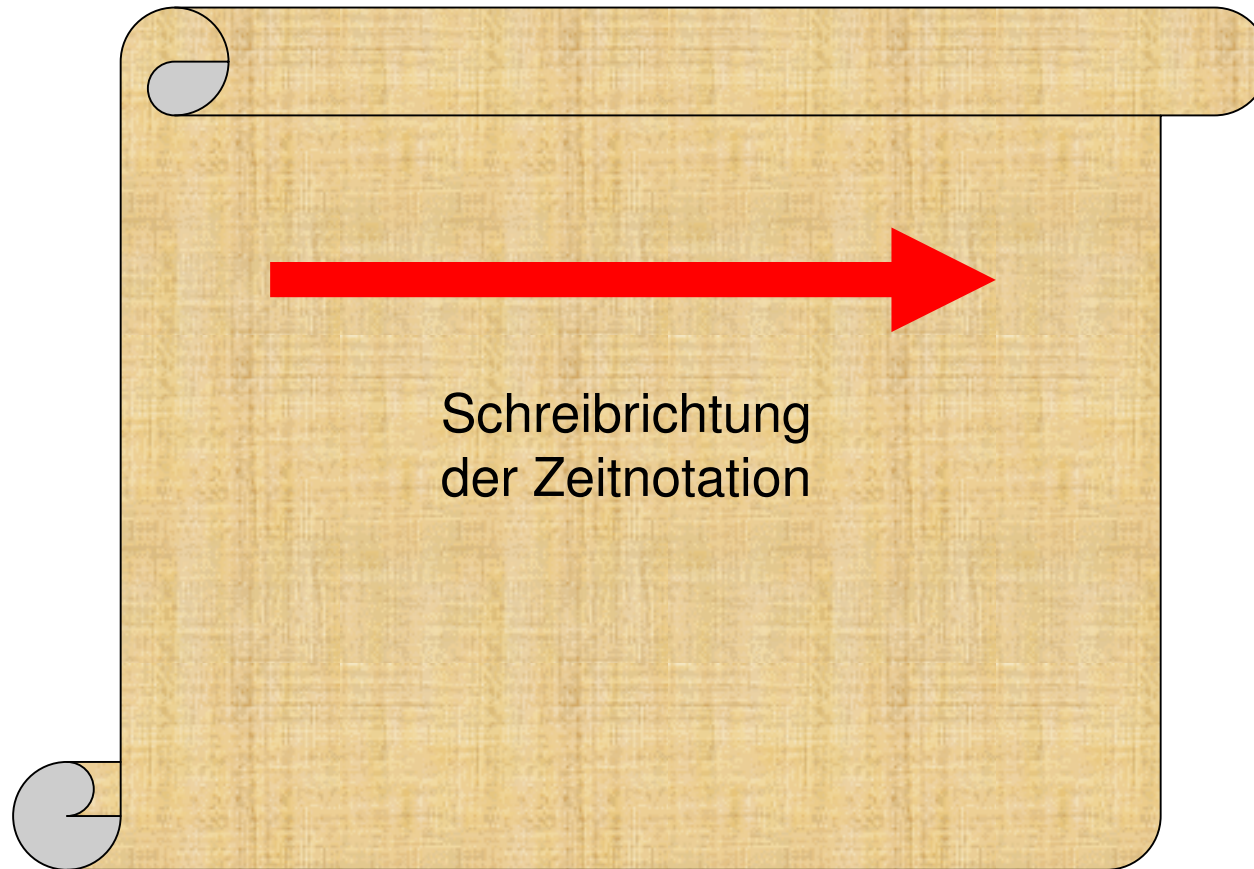

Schreibrichtung  
der Zeitnotation

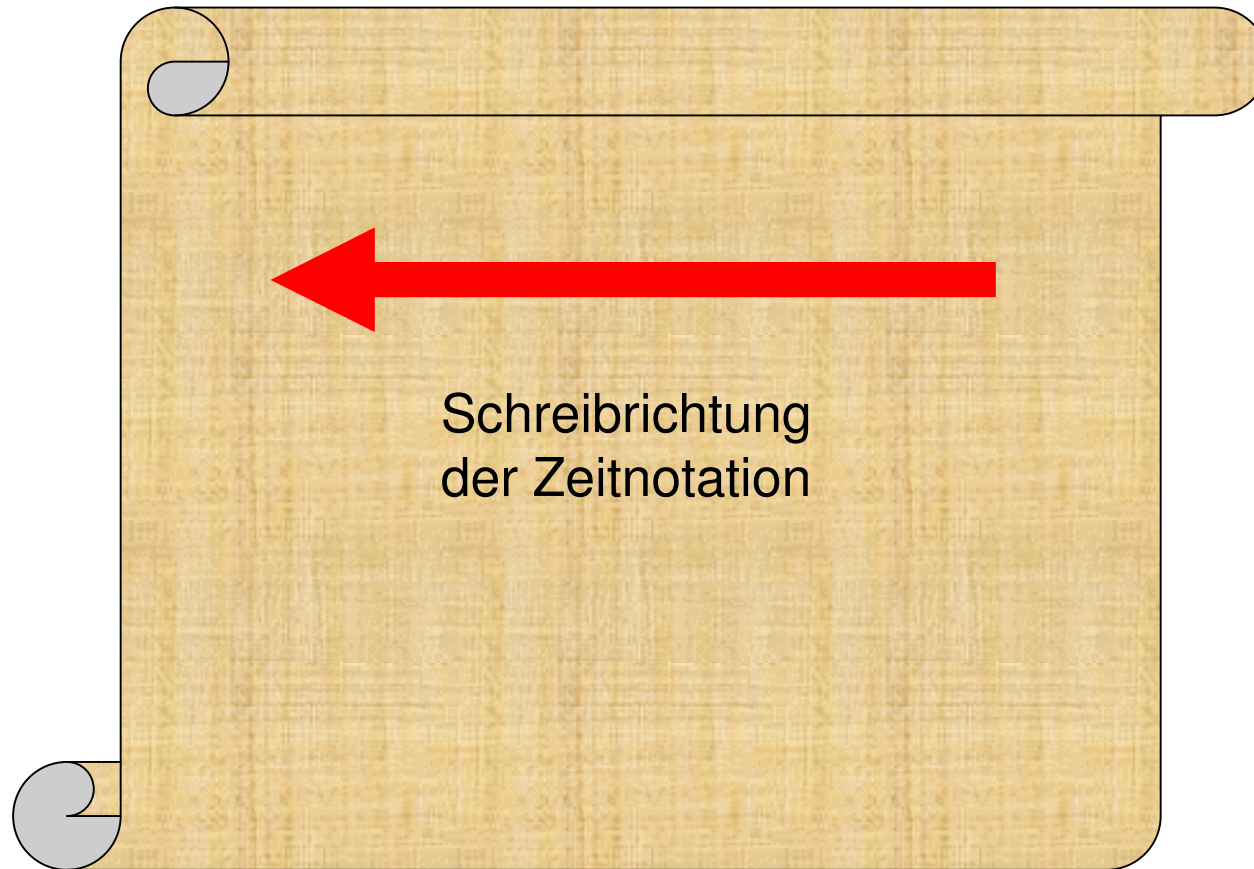

Schreibrichtung  
der Zeitnotation

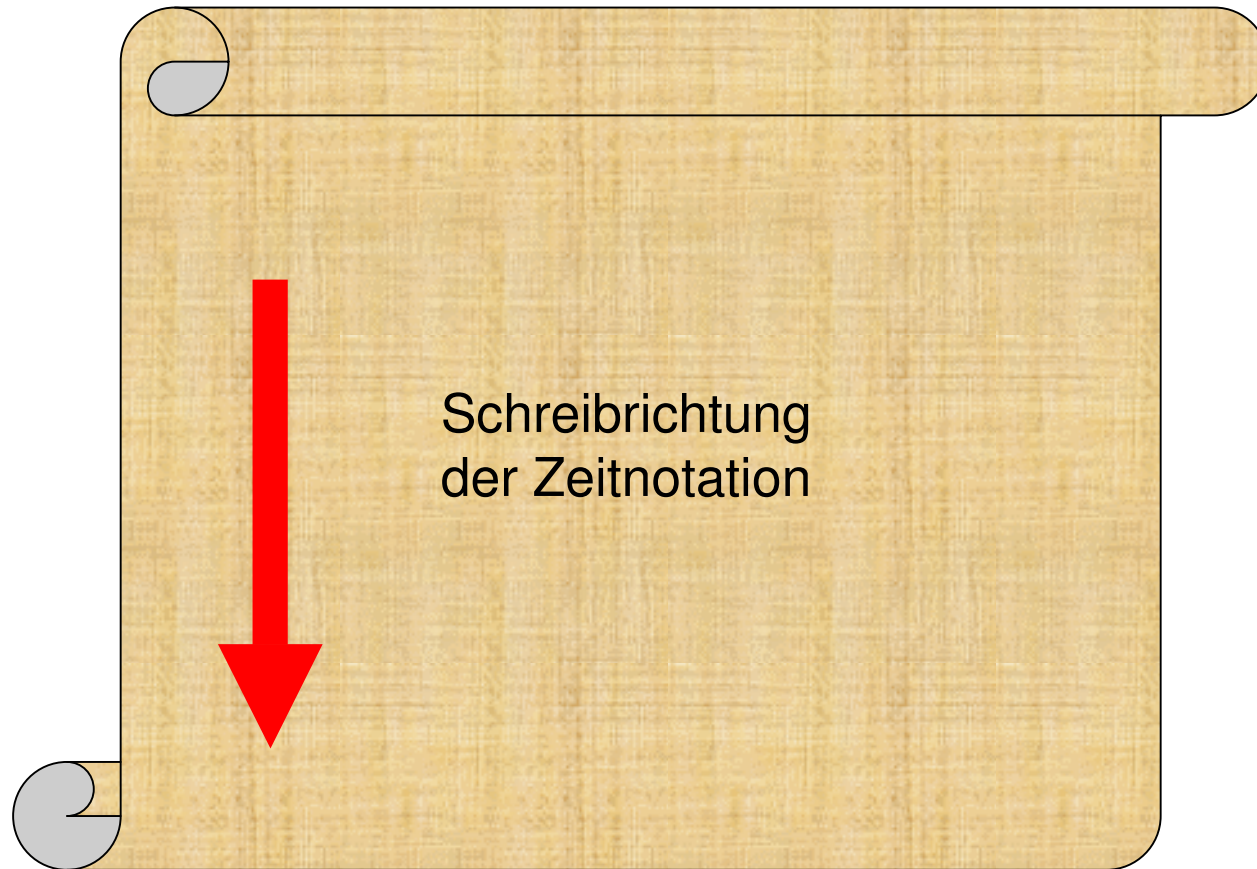

Schreibrichtung  
der Zeitnotation

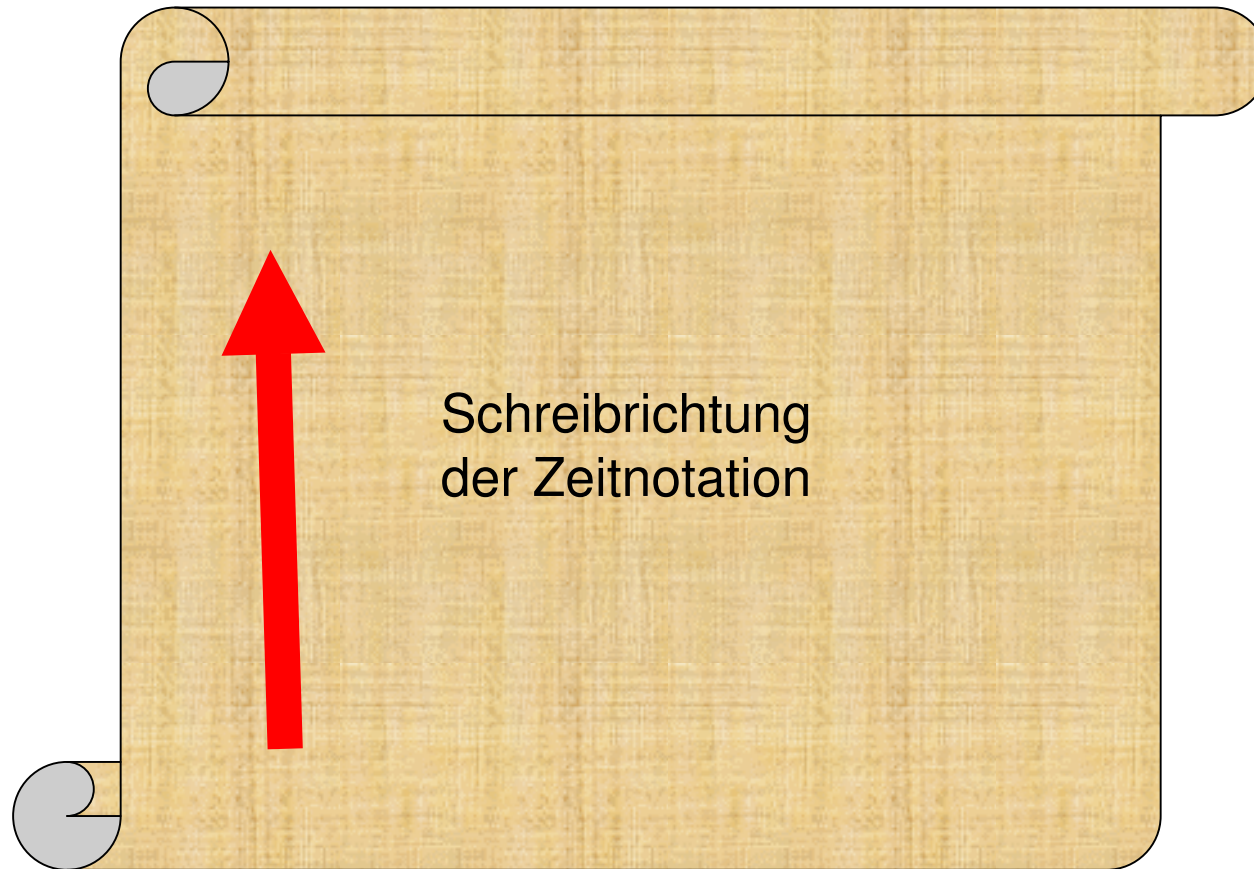

Schreibrichtung  
der Zeitnotation

# **vertikale Zeit-Notation**







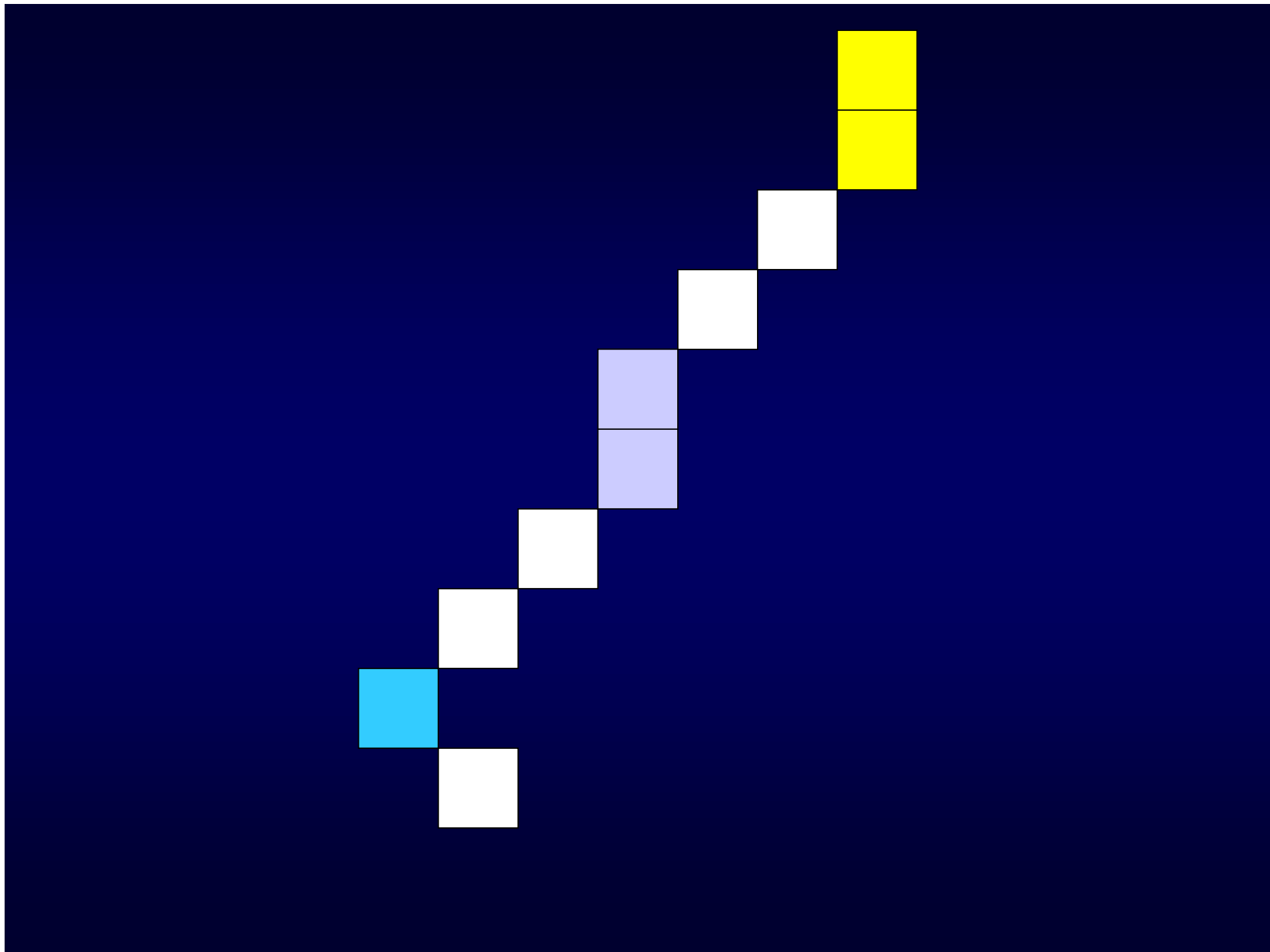



**vertikale  
Zeit-Notation**

**im virtuellen  
Wasser-Raum**



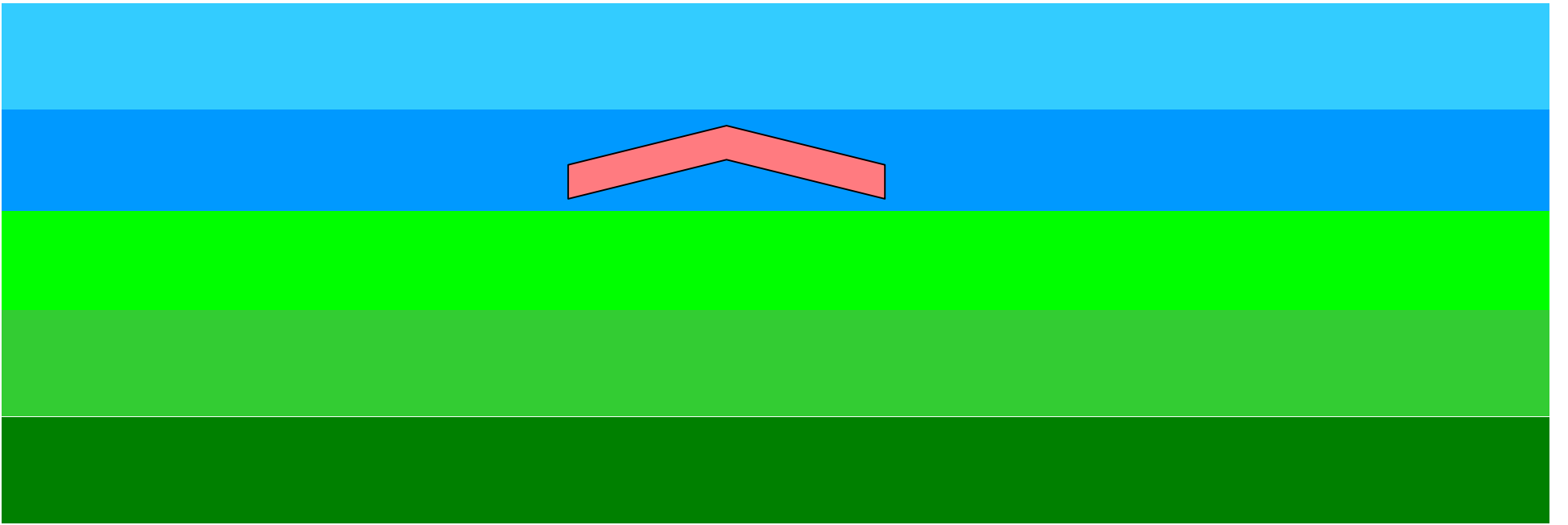

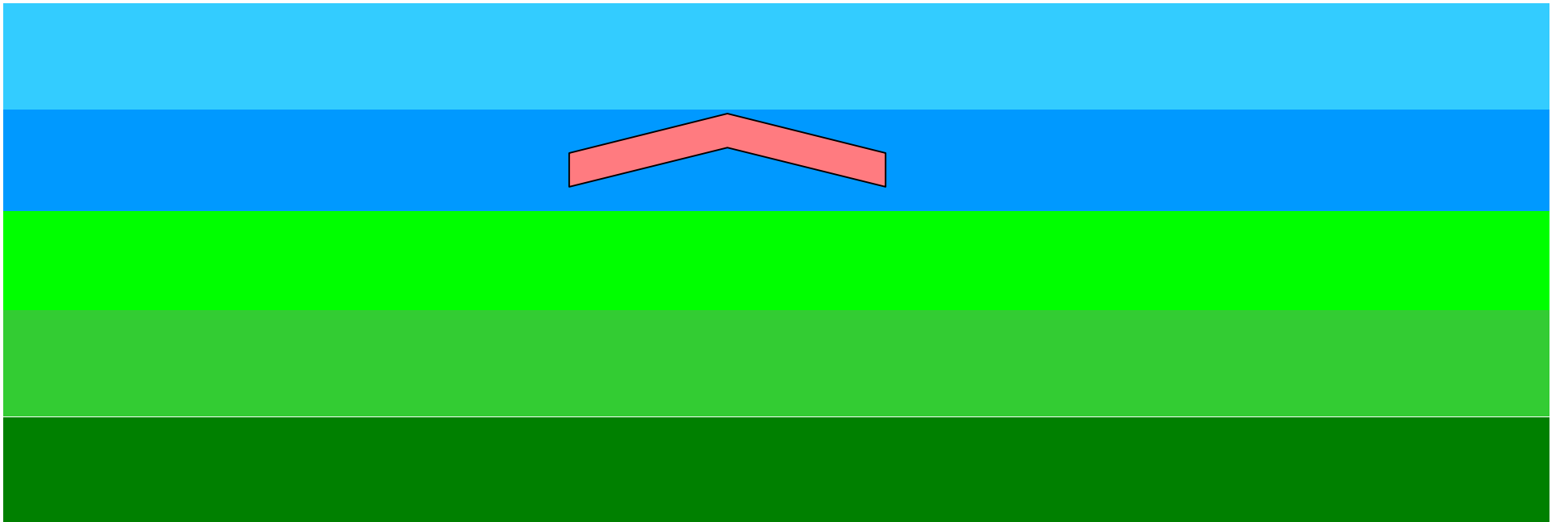

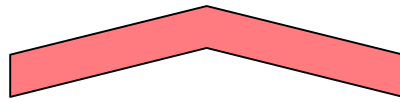

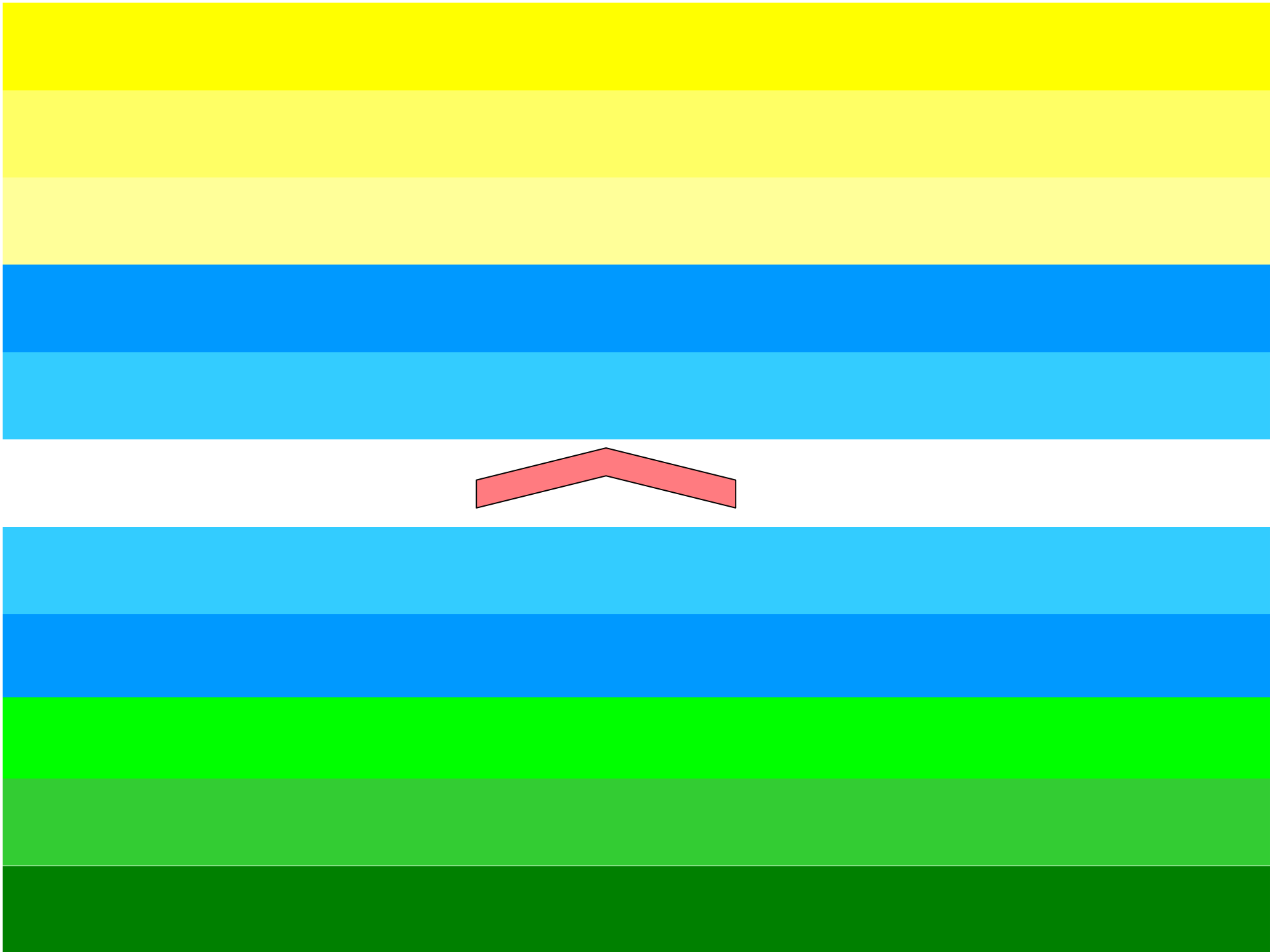



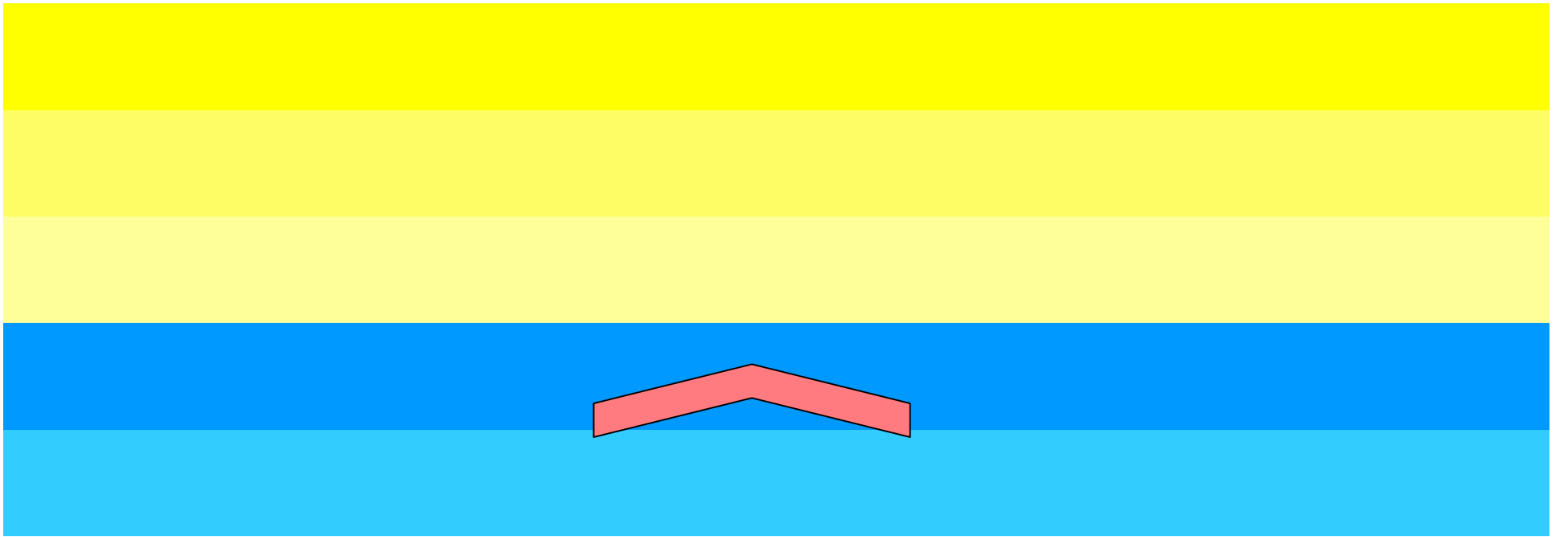

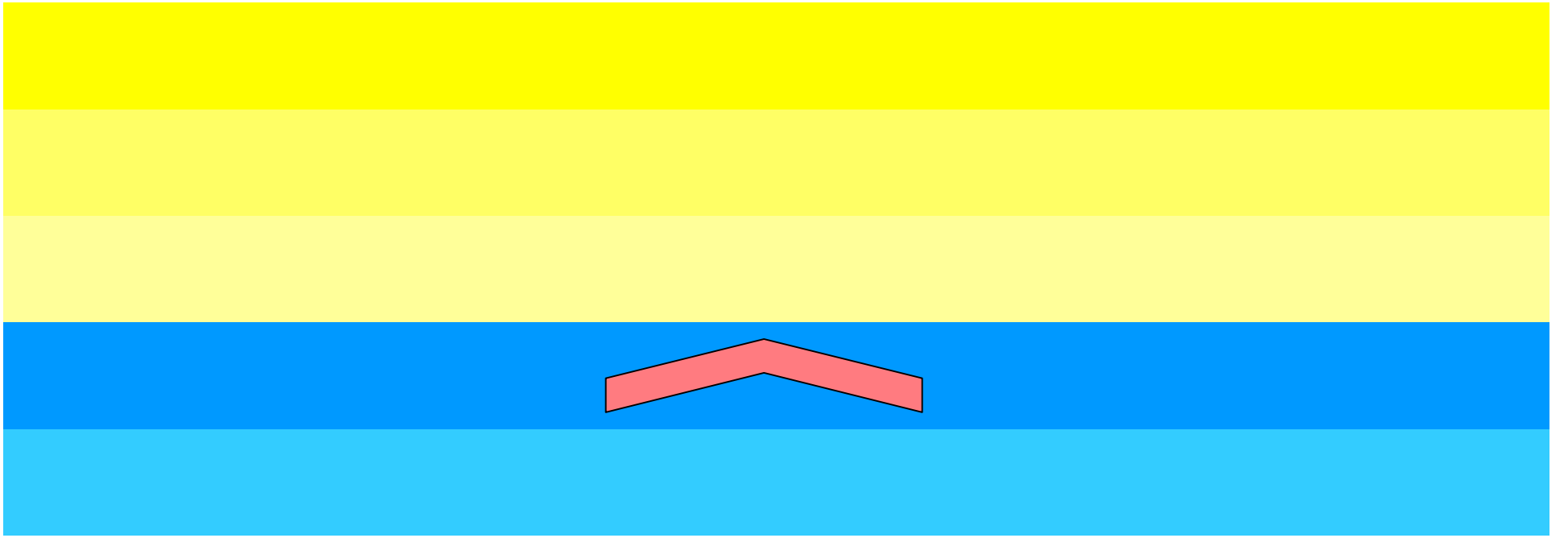

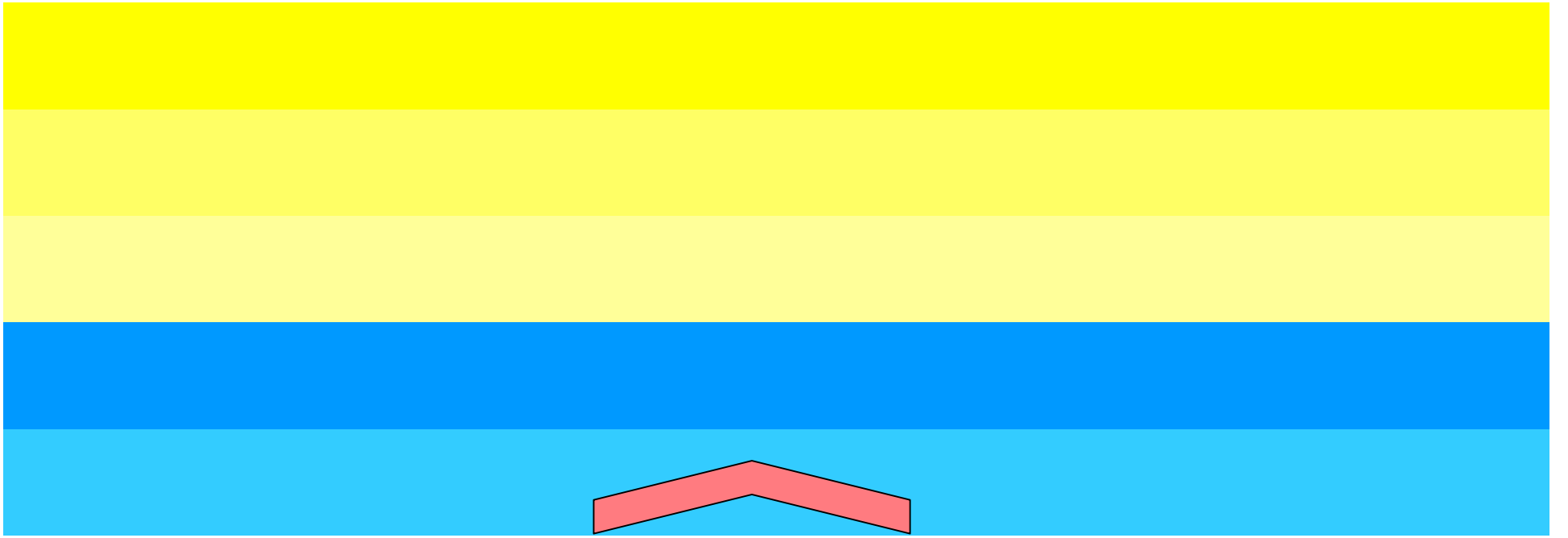

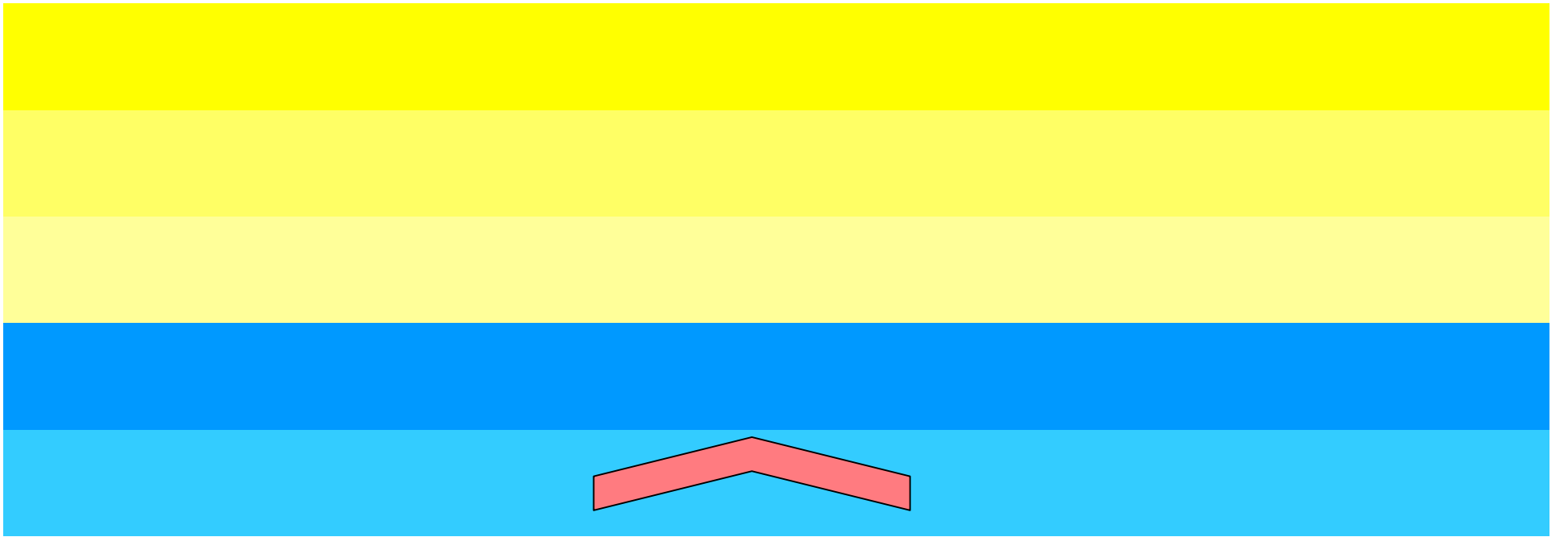

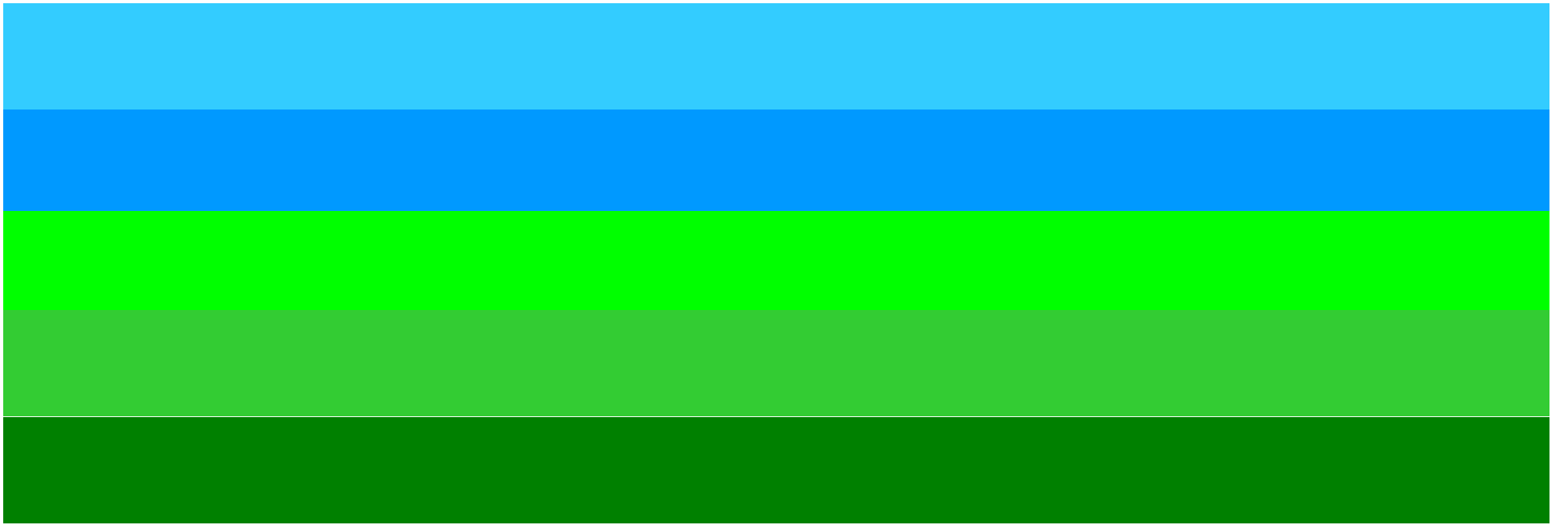
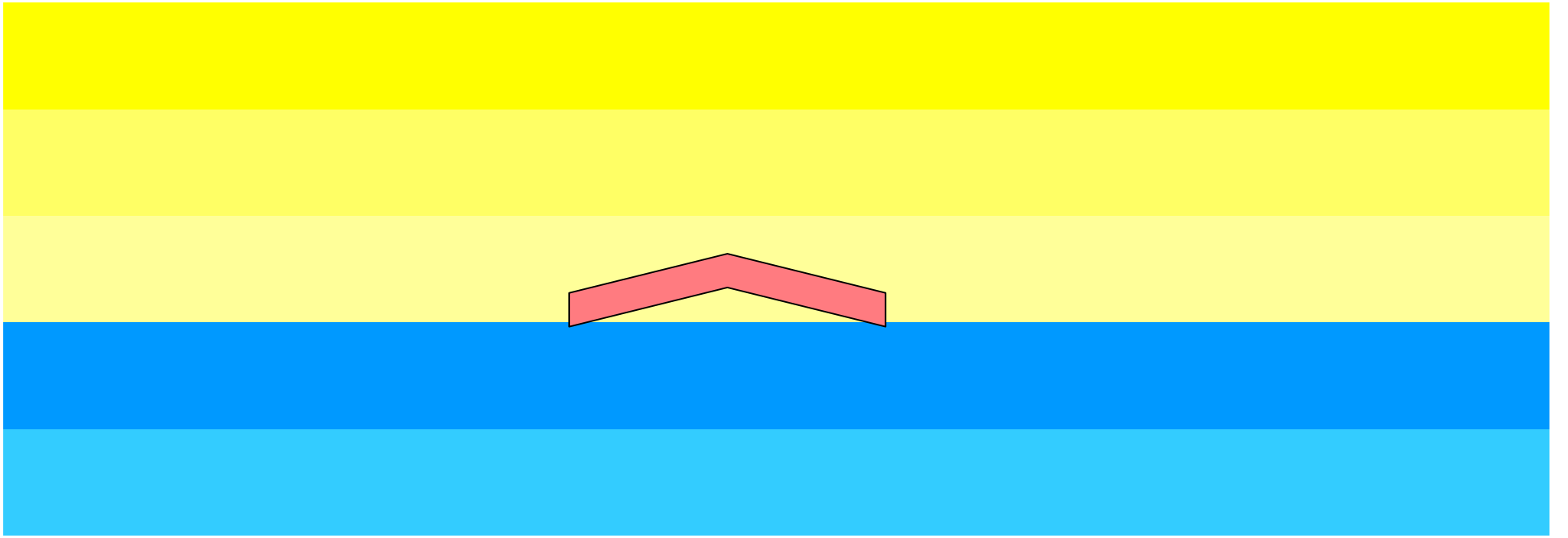

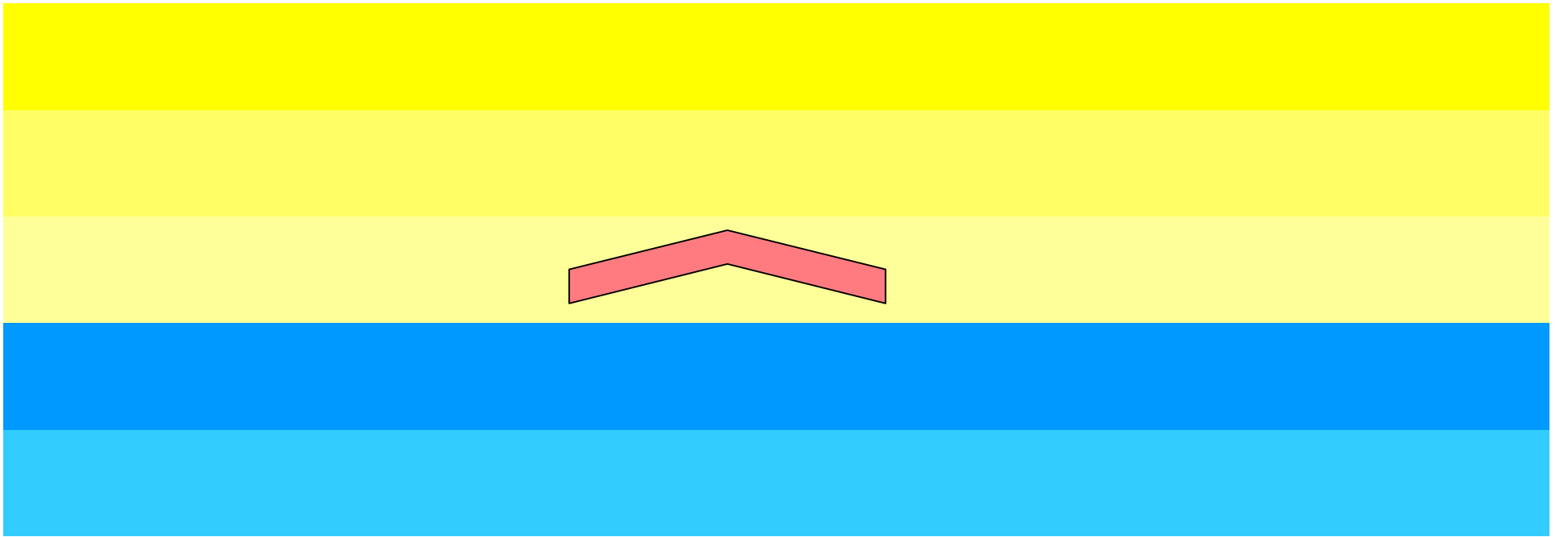

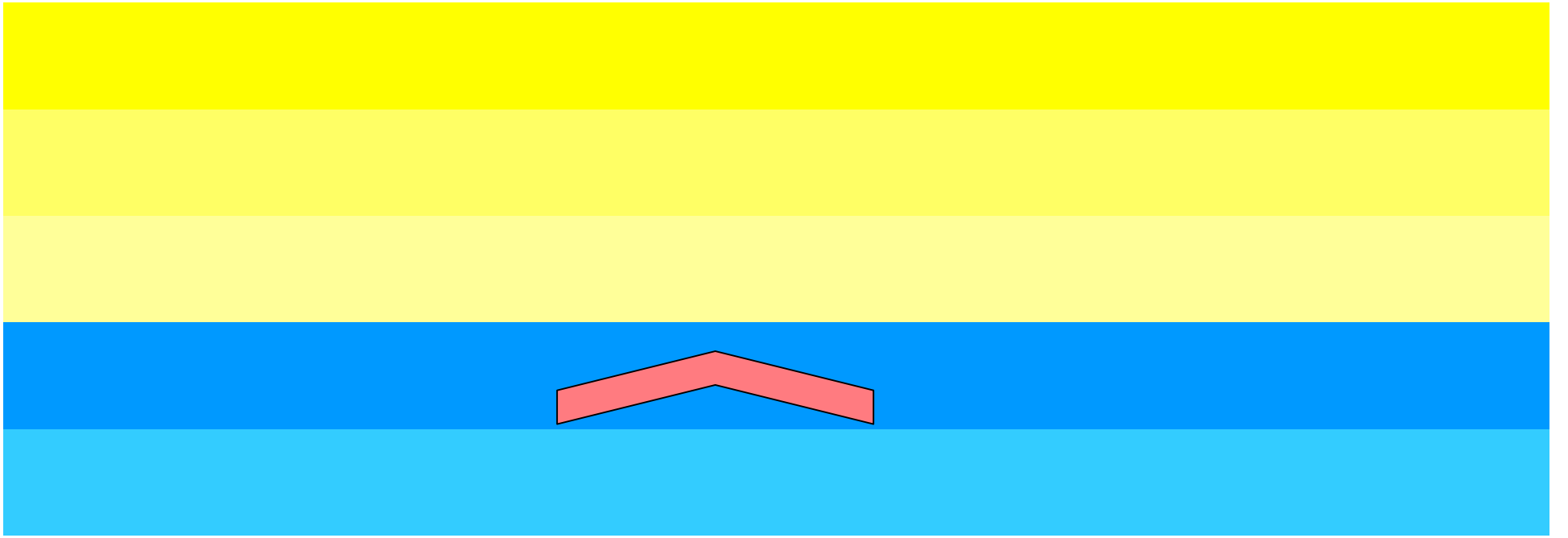

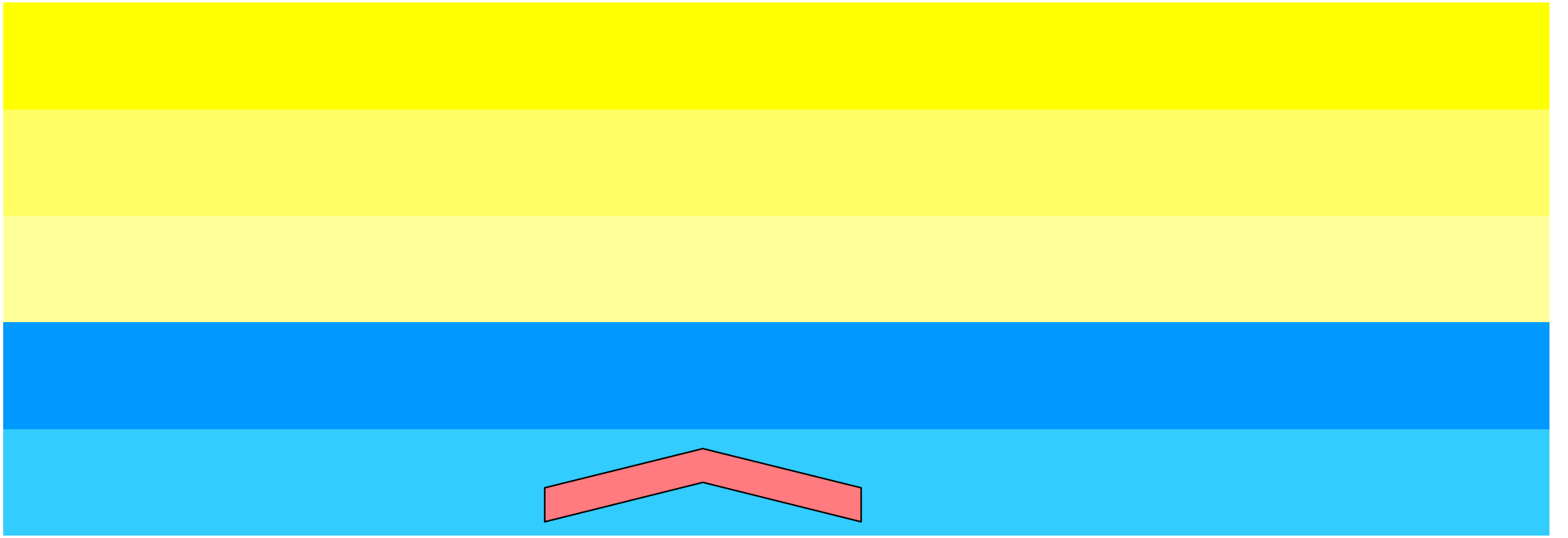



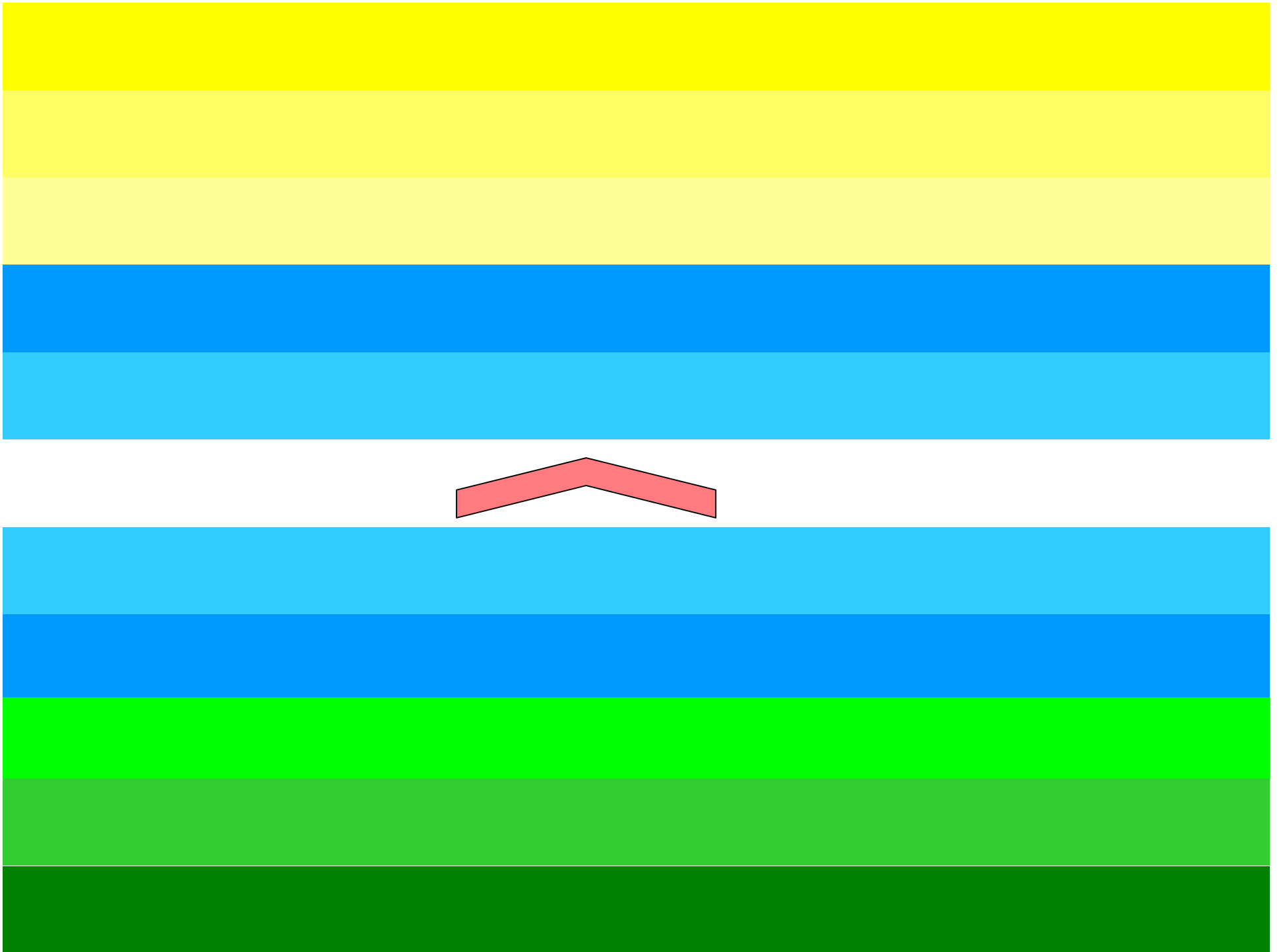

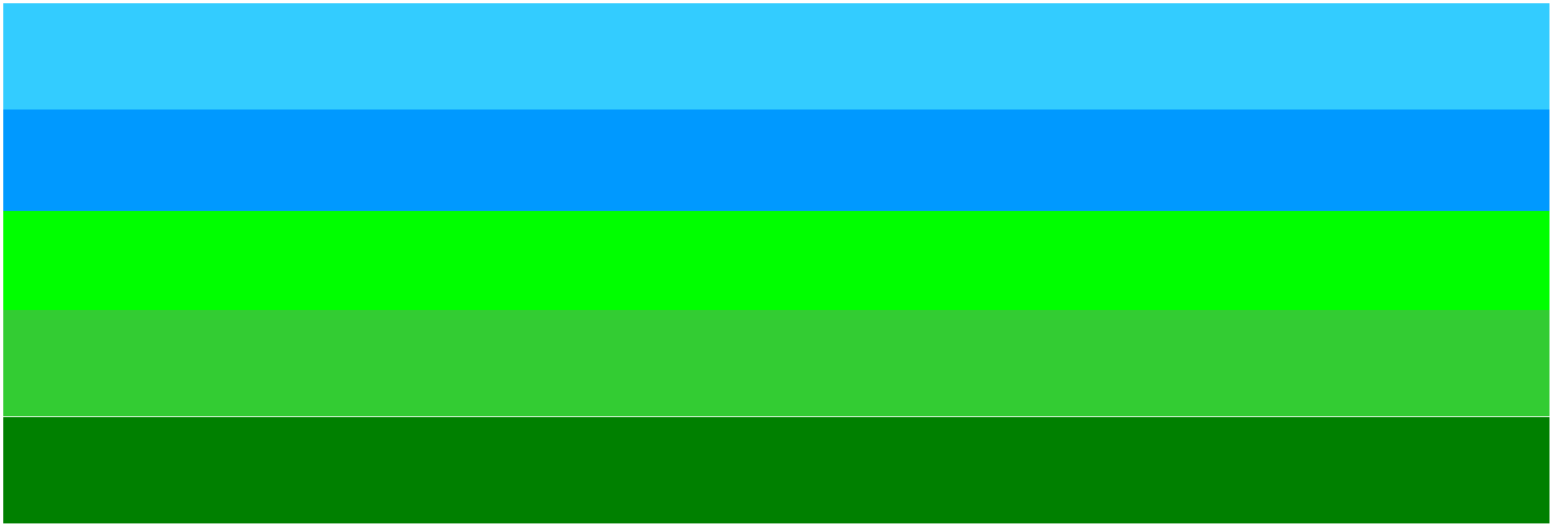

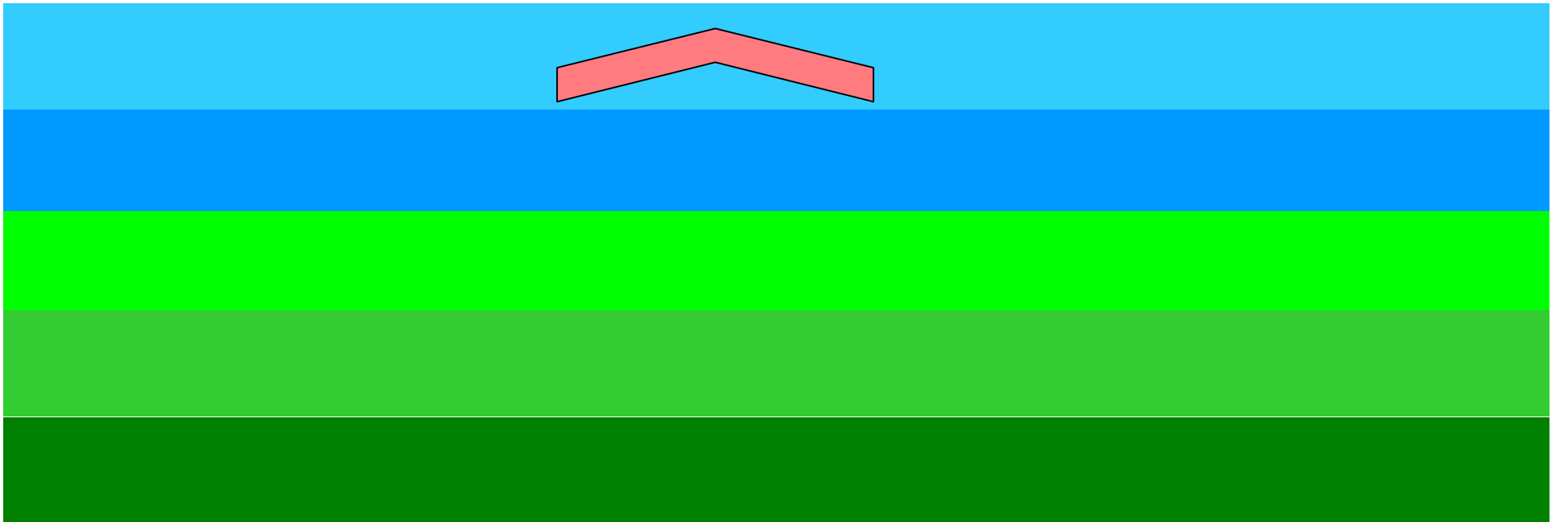
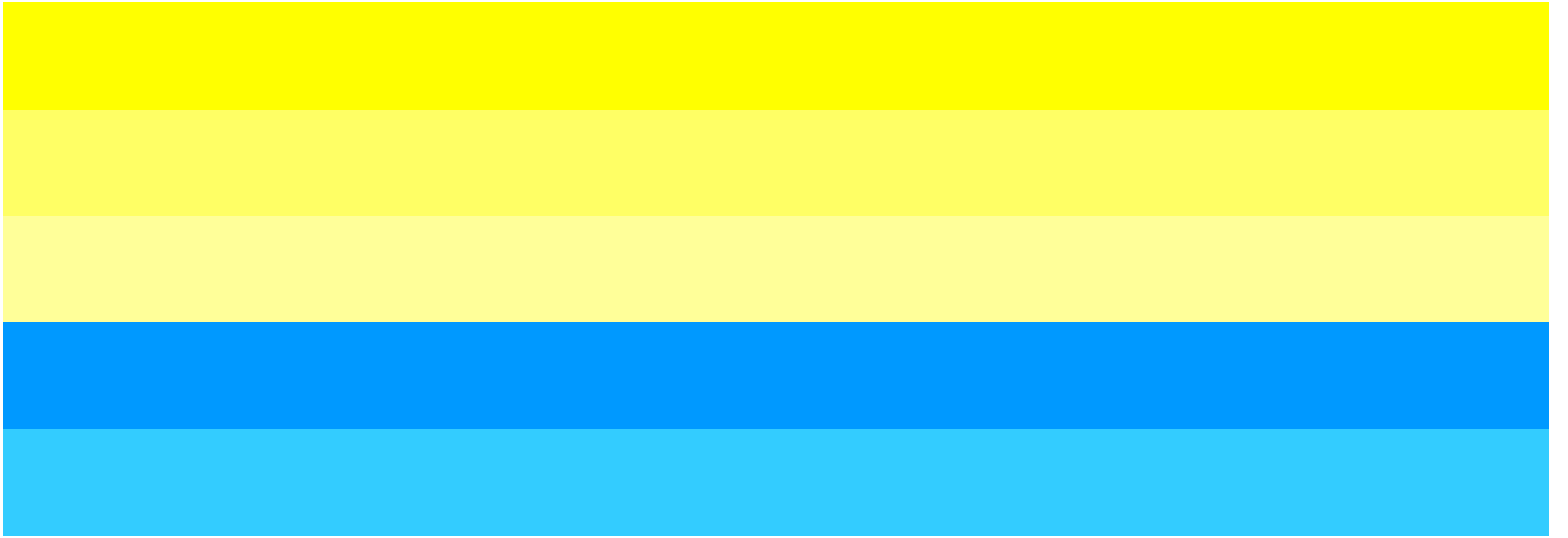

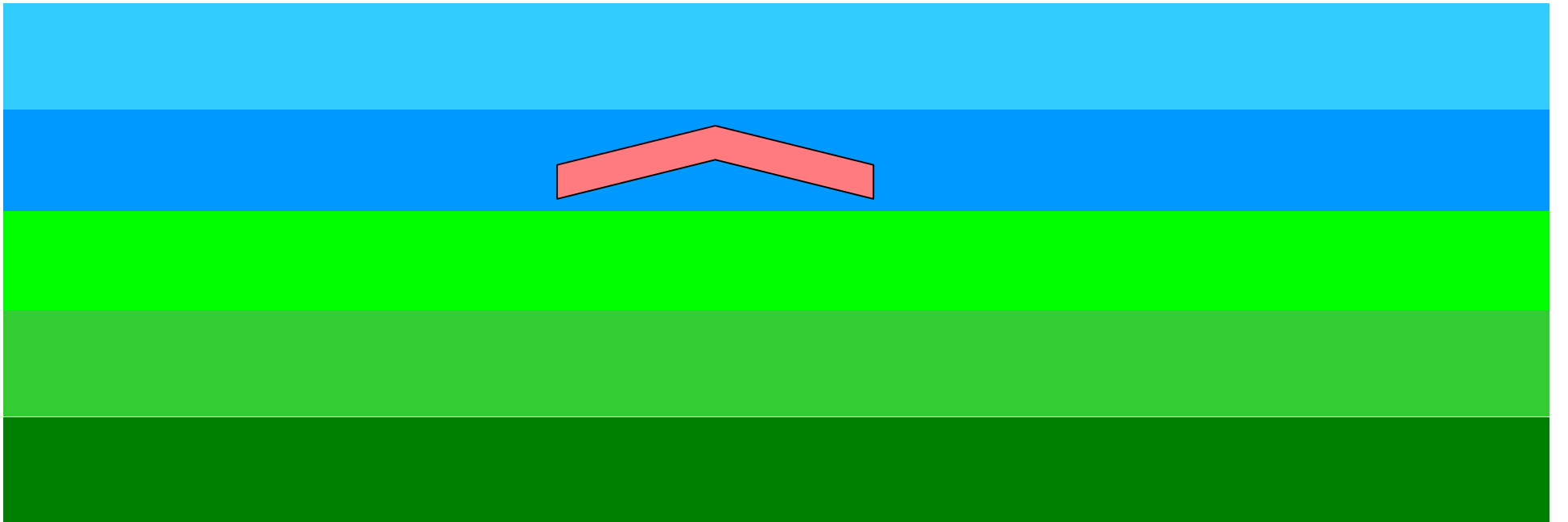

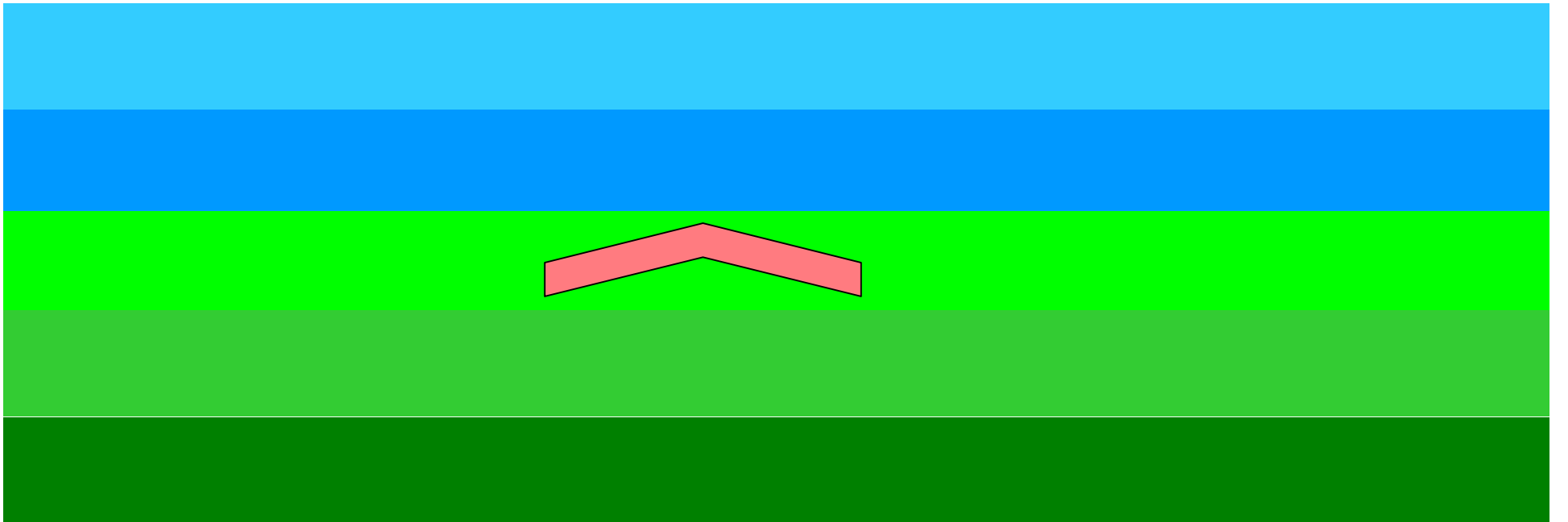

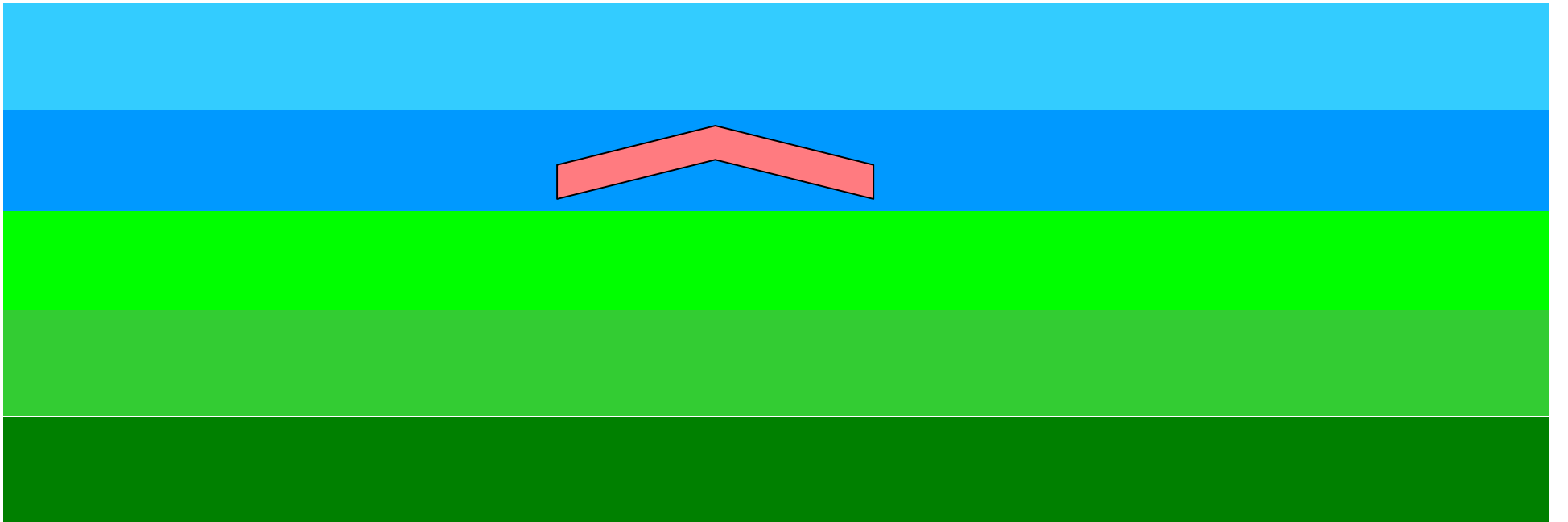

# **Historische Entwicklung der EU**

# Paris 1951 (1952)

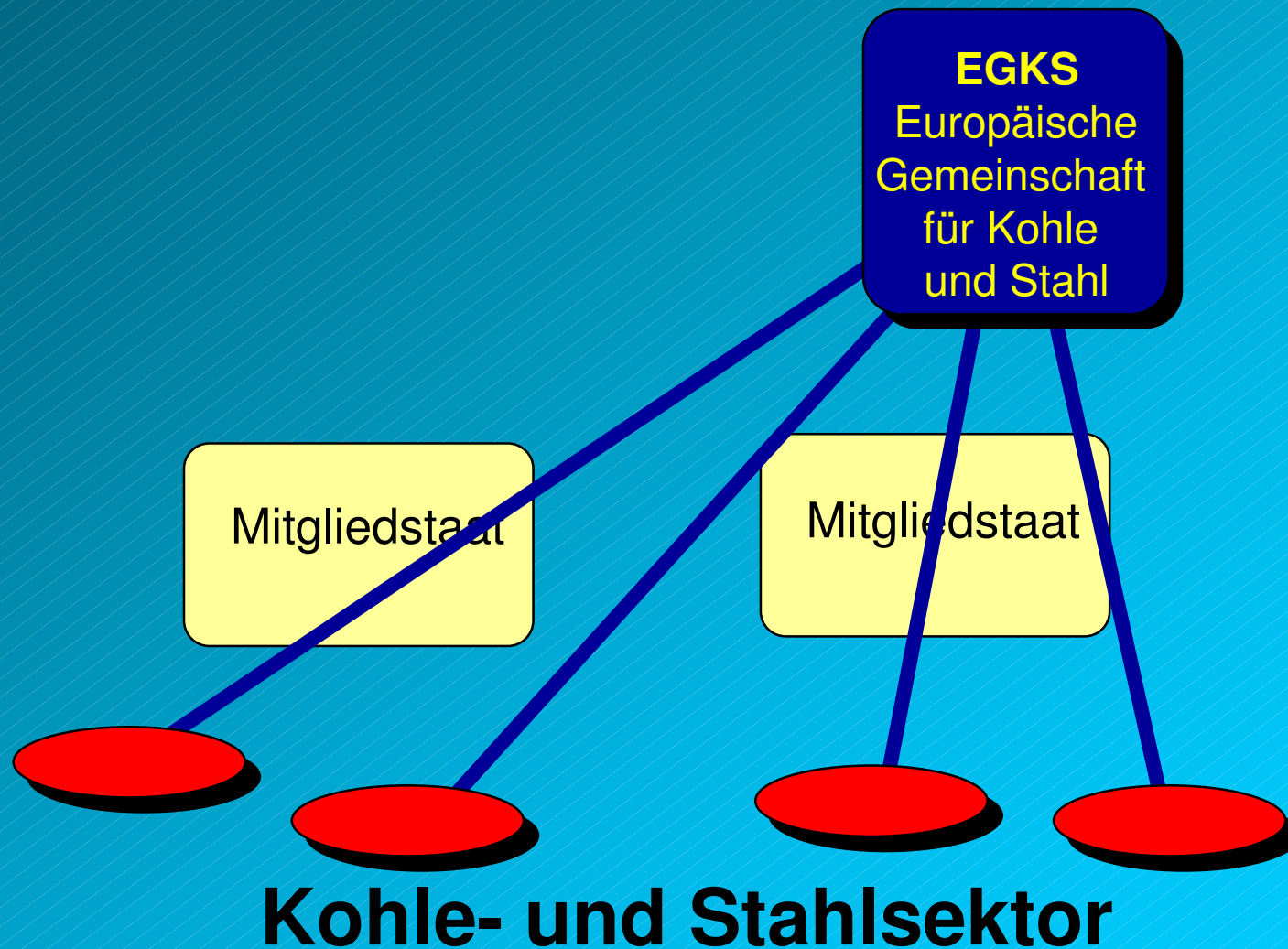



# Rom 1957 (1958)

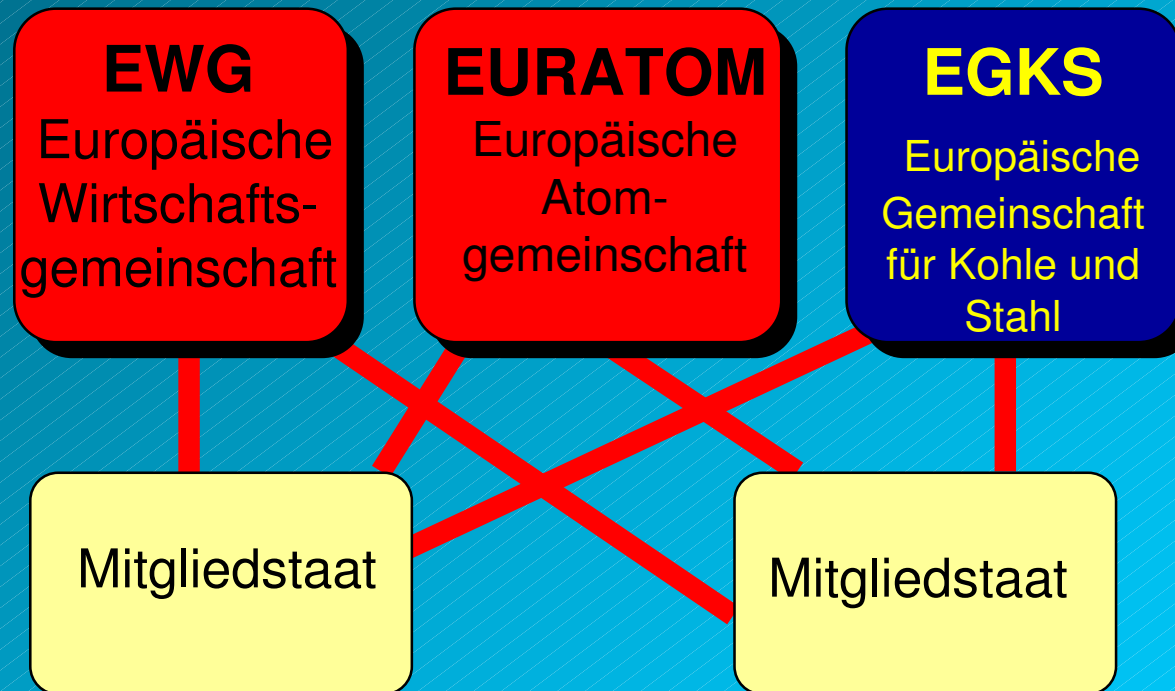

# Fusionsvertrag 1967



Gemeinsame Organe  
der drei  
Gemeinschaften

Mitgliedstaat

Mitgliedstaat

**EEA**  
**Einheitliche Europäische Akte 1986 (1987)**

Europäische  
Gemeinschaften

**EWG**

*Europäische  
Politische  
Zusammenarbeit*

Mitgliedstaat

Mitgliedstaat

**Binnenmarkt**

# Maastricht 1992 (1993)

## Europäische Union



Europäischer Rat

# EU

Europäische  
Gemeinschaften



1. Säule

GASP

Gemein-  
-  
same  
Außen-  
und  
Sicher-  
heits-  
politik

2. Säule

ZBJI

Zusammen-  
Arbeit im  
Bereich  
Justiz und  
Inneres

3. Säule

# Maastricht 1992 (1993)

## Europäische Union



Europäischer Rat

# EU

Europäische  
Gemeinschaften



1. Säule

GASP

Gemein-  
-same  
Außen-  
und  
Sicher-  
heits-  
politik

2. Säule

ZBJI

Zusammen-  
Arbeit im  
Bereich  
Justiz und  
Inneres

3. Säule

# Nummerierung Amsterdam 1997 (1999)

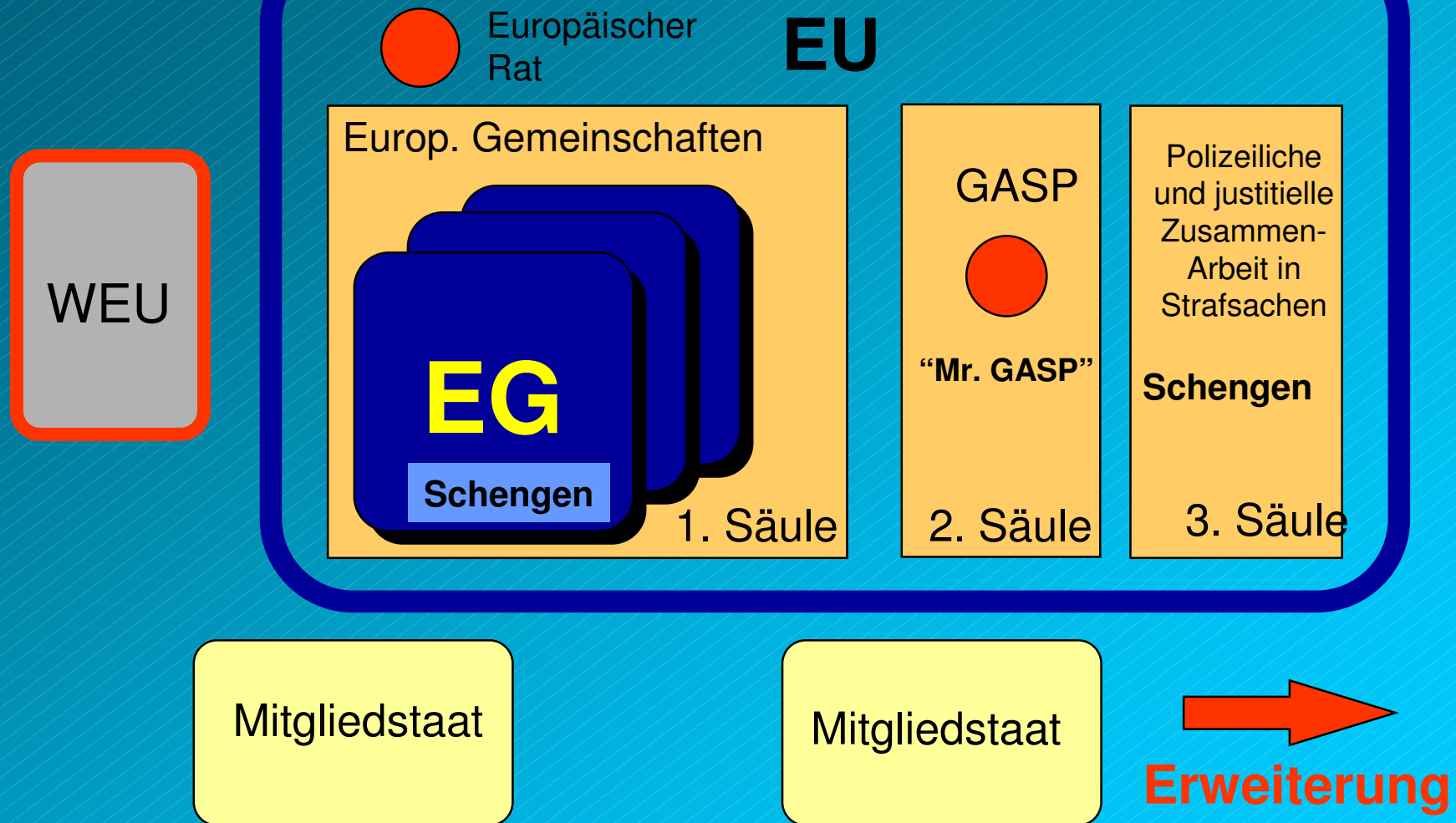

# Nizza 2000 (2003)



Europäischer Rat

EU

Europäische Gemeinschaften

*EGKS mit 23. 7. 2002 ausgelaufen*

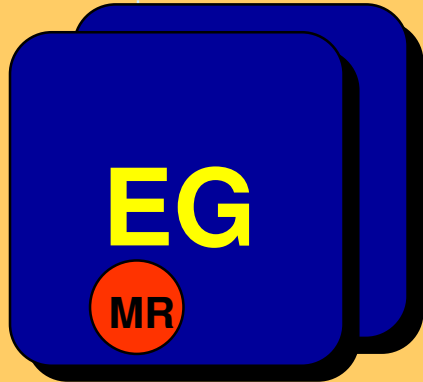

1. Säule

GASP

WEU

2. Säule

Polizeiliche und justitielle Zusammenarbeit in Strafsachen

3. Säule

Ziel: **Institutionenreform**

Mitgliedstaat

Mitgliedstaat

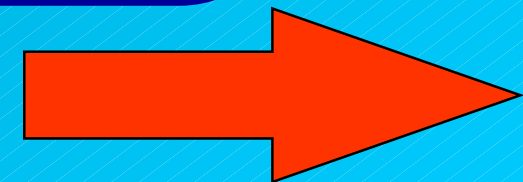

**Erweiterung**

**New Age**



2001 09 11:

neue

Weltlage

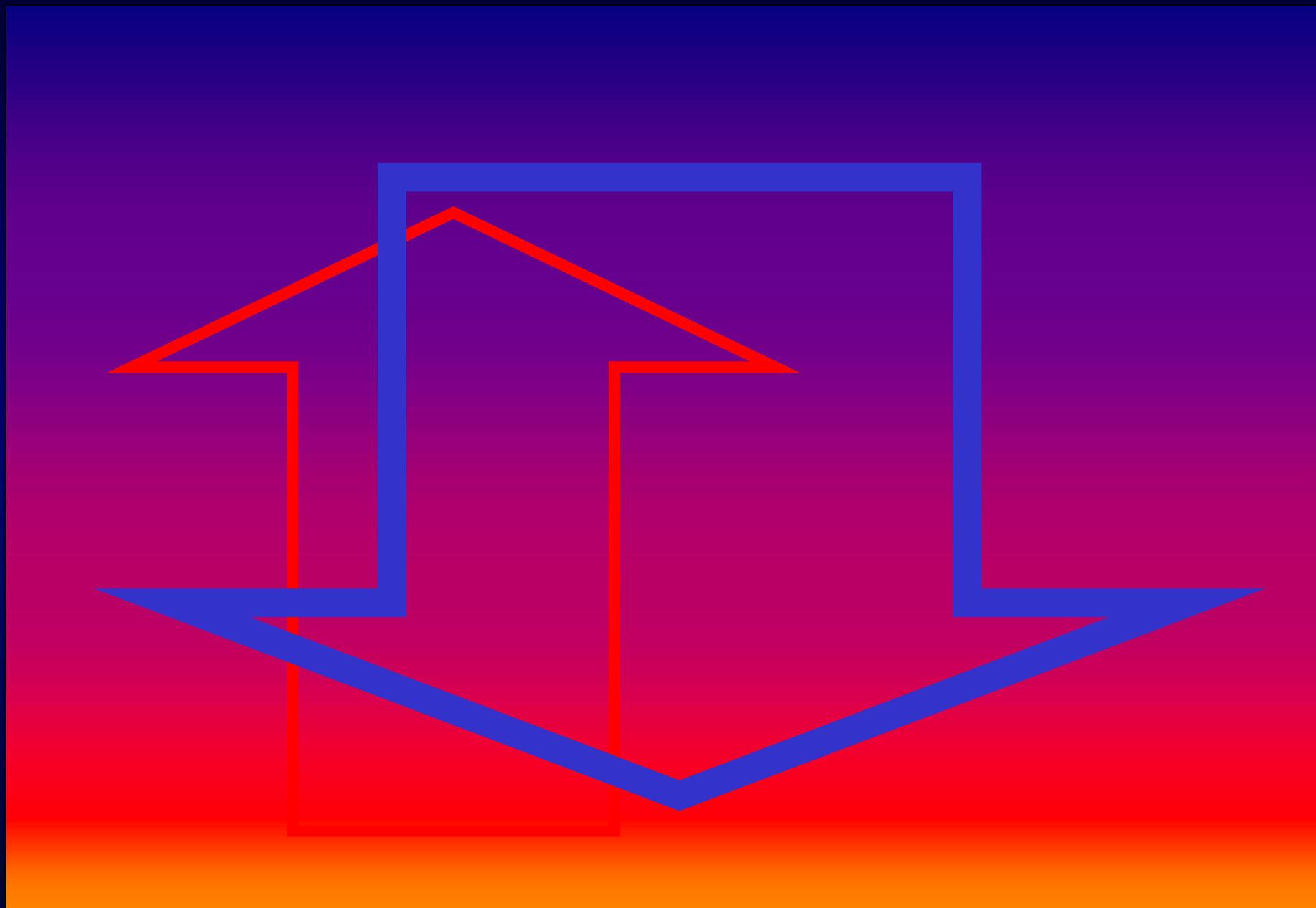

*Titanenkampf der Olympier*

1150

*Kreuzzüge*

1815

*Heilige Allianz*

2001

*neue Weltlage*





**QUO VADIS?**

**Danke  
für Ihre Aufmerksamkeit!**

A decorative graphic consisting of a thick horizontal blue line that spans the width of the slide. Below this line, several thin blue lines extend downwards and outwards from the line, creating a series of trapezoidal shapes that resemble a perspective grid or a stylized architectural structure.

[lachmayer@chello.at](mailto:lachmayer@chello.at)